

TABLE OF CONTENTS

PARTS LIST PD-10	5
1. Introduction to Instructions.....	9
Foundation	9
Foundation bolts.....	10
Installation Practices	10
2. Safety Precautions.....	11
Fiberglass	11
Construction and Operation Cautions	12
3. Special Assembly Instructions.....	13
Nomenclature	13
Locating Holes	13
Drilling and Bolting	14
Leveling the Foundation, Wall, and Base Rings	15
Leveling with Carpenter Level.....	15
Leveling with Water Level.....	16
Making the Observatory Circular, and maybe Centered	16
Stainless Steel Cable	17
4. Wall Construction.....	18
Wall/Base Ring & Semi-Door Assembly Preparation	19
First Ring Assembly.....	20
Installing First Ring on Foundation	21
Alternative Ways to Stack Wall Rings/Base ring	22
Base Ring Installation	23
Door and Hinge Completion	24
Latch Installation.....	24
Roller Mounting	25
Support Rollers	25
Side Rollers	25
Wall Bracing	26
5. Shutter, Rear Cover, DSR Preparation	27
Front Shutter Preparation	27
Security and Locks.....	28
Top Shutter Preparation and Latches	29
Top Shutter Restraint System J-Guides	29
Rear Cover Preparation	30
Electric Shutter.....	30
Shutter Catchers	30
Dome Support Ring (DSR).....	30
6. Dome Construction	32
Overview of the Action.....	32
Dome Quad Assembly	32
Rear Cover	33
Shutter Installation and Initial Operation	36
7. Finish Work	38
Shutter Restraint System.....	38
DSR Swingout Safety Brackets.	39
Soffit	40
Anti Rotation Bolts.	40
Caulking	40
Instruction Sheet	41
8. Problem Solving.....	42

Dome Rotation Problems	42
Shutter Engagement Problems	43
Shutter Dis-engagement Problems	43
Shutter Blow-off	44
Base Ring Service	45
9. Use and Care of your PRO-DOME	46

APPENDICES

Figures 1-24
 Bolt Hole Drilling Guide
 Shutter Pole Design
 Specifications
 Terms, Warranties,
 Disclosures
 Instruction Sheet

**INSTRUCTIONS FOR OPTIONAL
ITEMS**

Electric Shutter
 Electric Dome Drive
 Power Supply
 Digital Dome Works
 Rectangular Skirt
 Circular Skirt

PARTS LIST PD-10

FIBERGLASS PIECES

Right Quadrant (2)
Left Quadrant (2)
Dome Support Ring Sections (4 w/door swingout)
Rear Cover (1)
Top Shutter (1)
Front Shutter (1)
Base Ring Sections (6, includes molded door and two stub sections)
Wall Ring Sections (6, includes molded door and two stub sections), for each ring

FITTINGS AND HARDWARE

Stainless Steel Carriage Bolts
Stainless Steel Flat Head Bolts
Nuts, washers
Front Latch (28 in long)
Rear Latch (20 in. long)
Shutter Catchers (2)
Wheels and Hardware (31) NOTE: 29 wheels if ED-10 ordered
Side Rollers & Bolts (16)
Handles (2)
Shutter Restraint Hardware
Shutter bearing strips (4 pcs)
Fiberglass Surface Cleaner
Front Shutter Edge Molding
Rear Opening Cover (Soffit)
Shutter LynchPins (2)
Semidoor hardware (upper and lower latches, piano hinge, DSR safety bracket, bolts)
Caulk
Instructions

TOOLS AND HARDWARE TO BE PROVIDED BY INSTALLER, NOT INCLUDED WITH PD-10

3/8 in electric drill with set of bits
(2 drills are even more efficient)
Countersink (82 deg. preferred)
File or rasp
Metal rule (25 ft. or longer)
Carpenter level or water level
Hand tools: clamps, screw drivers, socket wrench set, etc.
Large metal square & straight edge
Duct tape
Caulking gun
Gloves, eye protection
Work table (e.g. sawhorses & plywood)
Extension cord(s)
Step ladder
Foundation bolts and fender washers
Thin shims and spacers for leveling **
Several lengths of 2 x 4s and 2 x 2s

** Shims – have several thicknesses available (such as 1/8", 1/4"). The design shown below is useful because you can slide the shim in under the fiberglass and around a bolt without having to remove everything.

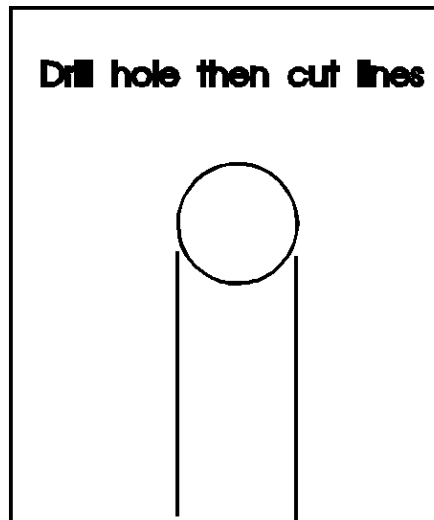

TYPICAL HD/PD ASSEMBLY PROCESS

03/11/97

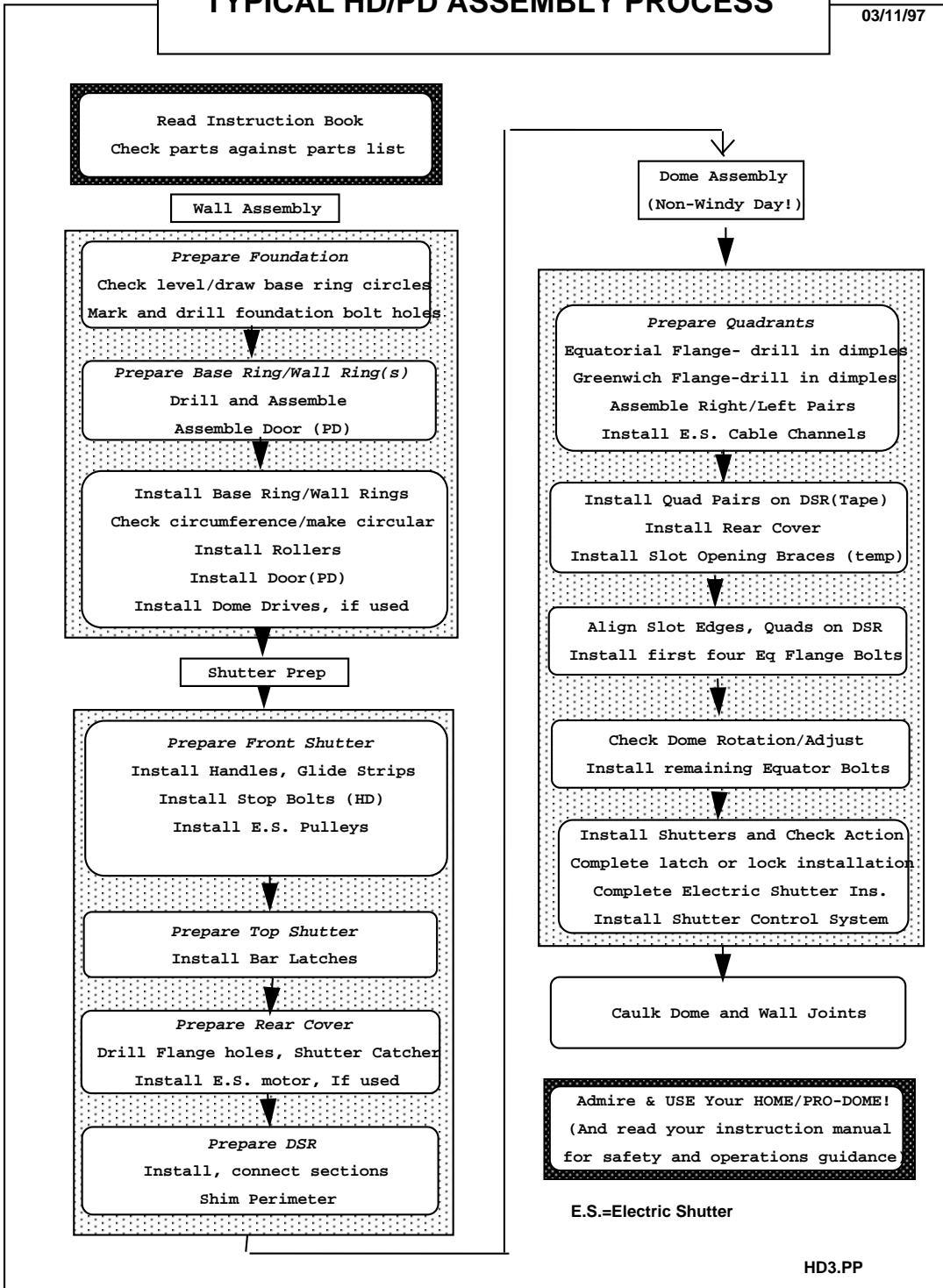

E.S.=Electric Shutter

HD3.PP

STAINLESS STEEL BOLT COUNT FOR PD-10

BOLT LOCATION	2.25" FH*	1.5" FH	1"CB	3/4"FH	3/4"CB	NUTS	WASHERS
BASE RING D.S.R.			8			8	8
DOME- EQ. FLANGE				20		20	20
GREENWICH FLANGE			10			10	10
REAR COVER FRONT/REAR LATCH		14				14	14
SHUTTER CATCHERS			4			4	4
HANDLES			2			2	2
WHEELS	31					31	
SHUTTER STOP BOLTS			2			2	2
TOTALS *3/8" bolts	31	14	26	20	9	100	69
PD-10 WALL RING BOLTS (for each ring)			28			28	28

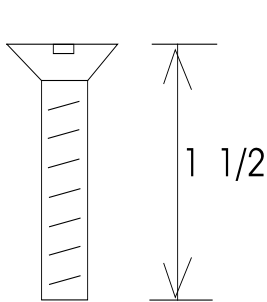

FLAT HEAD SCREW/BOLT

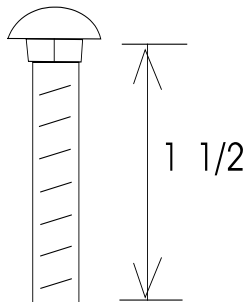

CARRIAGE BOLT

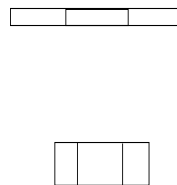

NUT & WASHER

SCREW LESSON
 The outer diameter of small screws is a number such as #6, or #8. #8 is bigger than #6. In larger sizes, the diameter is in fractions of an inch (e.g., 1/4-inch). The second number (e.g., 6-32, 1/4-20) is the number of threads per inch. The third number (e.g., 6-32x1/2) is the length in inches.

1. Introduction to Instructions

The assembly of the PRO-DOME involves several steps. These include:

- obtaining necessary permits
- building the foundation
- assembling the wall (if any)
- installing the base ring and rollers
- assuring that the top of the wall is level
- preparing shutters and rear cover
- assembling the dome
- installing the shutters
- installing the fittings and hardware

In some areas, building permits are needed for the installation of the PRO-DOME, although there are sometimes exemptions for structures the size of the PD-10. If you need a permit, you will need to apply for it, and include sketches of the proposed location and installation. If the PRO-DOME is to be installed in or on your house or other inhabited building, special fire or other codes may apply in addition to structural integrity requirements. Check with the local officials: it is much easier to handle the questions before you build, than to find out later you are in violation of the local law.

Foundation

FIG 4,5,6

The PRO-DOME must rest on a secure foundation if it is on the ground, or framing support if it is to be installed on a deck or other structure. The major purpose of the foundation is not to support the weight, since the PRO-DOME only weighs about 350 pounds. Rather, its purpose is to provide stable support under all environmental conditions. In addition, in most cases, the foundation system must provide some means of leveling the observatory.

The foundation must support the observatory so that the walls and dome do not twist as the ground freezes or thaws or becomes dry vs. wet (this could cause the dome to become hard to turn).

The foundation must hold the PRO-DOME down in the case of severe wind. Depending on the area of the country, hurricane or other winds 80-mph (or more!) can occur, so building codes require that buildings and their foundations resist such winds. (An 80-mph wind on the PRO-DOME can generate a force of over 1000 lb.)

The foundation may be part of a building or house, a deck, a ring foundation, piers into the ground, or a concrete pad (often with wood or carpet covering). If you want suggestions, please contact us for more information on constructing foundations.

Foundation bolts

Selecting the appropriate foundation bolts to hold the bottom ring to your surface is your responsibility. The most common bolts are lag bolts into anchors in a concrete pad, or carriage bolts through a wood deck. In all cases, it is absolutely necessary to use washers at least 1 1/2-inch diameter under the bolt heads. In general, we recommend using 3/8-inch diameter bolts spaced about 16-18 inches apart along the bottom flange. Lag bolts should penetrate the pad or deck at least two inches. Be sure to allow enough length in case you need to use shims under the wall or base.

Installation Practices

Many of the installation steps take longer to read than to do. While no complex carpentry or other skills are needed, you will need to perform some measurements, check that pieces are level and straight, locate and drill holes, and install bolts. Sometimes edges of fiberglass may need to be sanded or trimmed. However, no experience is needed in working with fiberglass, and no application of fiberglass or resin needs to be done. None of the pieces weigh more than about 45 pounds, so even though they are bulky, they are relatively easy to handle.

We would strongly urge that you have a second person helping you. This allows you to check on each other, and will help avoid mistakes. The second person can help a great deal in holding items in place while the first drills holes and installs bolts. And finally, working together makes the job more fun!

Before beginning construction, both you and your assembly partner should read through the directions and study the pictures. Note especially the terminology that we use for the various parts. We urge that you not try to build the dome in an order different from that in the instructions: some of the short cuts that look attractive have traps in them (we know - we've gotten stuck!).

Finally, if you make a mistake, don't panic. In most cases you can just take the components apart, drill new holes, and do it over. If you want to, you can always go back later and patch any mistakes with resin (that is one of the virtues of fiberglass!). And if you get really stuck, give us a call and we will try to help.

2. Safety Precautions

Constructing a PRO-DOME requires you to follow several safety precautions and use common sense, since the activity does include mechanical and manual operations. Care is needed in the use of tools and you should follow the precautions provided by the manufacturers of any tools you may use. Since you will be constructing a small building, you will need to use stepladders: so be careful. While the fiberglass parts are not very heavy, they are bulky: use care in handling them so that neither you nor the parts are injured. Carefully read all the instructions, and think through your activities before you commence. Make liberal use of props, tape, clamps, or other aids in the construction.

CAUTION

If the dome is to be installed on any support or wall more than three feet above the ground, or in a location with difficult outside access, we **STRONGLY** recommend that you pre-assemble the base ring, dome, shutters, and all fittings on the ground. You will then be assembling the dome in a convenient and safe situation. Once pre-assembled, it only takes 30 minutes or so to disassemble the parts. You can then reassemble in place, knowing how the parts fit together, and with direct experience in handling the pieces.

Fiberglass

Fiberglass is really a misnomer: the material is fiberglass reinforced plastic (FRP). In our case, the plastic is an isophthalic (polyester) resin (not epoxy). In its "raw" state, resin is a syrupy liquid. After mixing about 15 drops of catalyst per ounce of resin, it hardens in about an hour. Because the hardened resin is somewhat brittle, it is reinforced with fiberglass for strength, and to prevent the propagation of cracks. The fiberglass can be in the form of woven material which has the resin spread onto and into it, or long fiberglass strands which are chopped into 2 inch pieces, then mixed with resin that is sprayed into a mold.

Fiberglass has many virtues, but also two potential problems:

FIBERGLASS IS FLAMMABLE

FIBERGLASS CAN IRRITATE THE SKIN

Yes, fiberglass will burn, or rather, the plastic in it will burn. Once started, it does burn very hot (you might want to try a 1 square inch piece in a fireplace to see). Therefore, use common sense as you would with wood or any other flammable construction material. Keep fire and open flame away from all parts of your PRO-DOME. Also, do not let fiberglass dust or trimmings accumulate. Be especially careful about this where there is any risk of flame or fire.

The fiberglass within the FRP is glass, and it can cut or abrade the skin. Sharp edges of the dome pieces can cut, so be careful. Whenever handling FRP pieces, always wear

gloves to be on the safe side. Of course, the surfaces of the FRP are smooth, because they have been coated with a layer of resin (called Gel-coat) that covers the glass.

Fiberglass dust can irritate the eyes and skin. When cutting or trimming or filing or drilling -- in short, whenever doing something to the FRP that makes dust -- always use gloves and eye protection. Also, wear a long sleeved shirt and long pants. In addition, be sure to change your clothes and wash thoroughly when you are done the dusty part. If there is lots of dust, change how you are doing things to reduce the dust exposure! Reasonable care is all that is needed; however, failure to follow reasonable care could lead to eyes or skin that itches for a day or so. Hand lotion can help relieve itchy skin. If itching persists, see your physician.

Construction and Operation Cautions

During construction and operation, there are specific cautions that must be followed. The PRO-DOME observatory is not a toy, so be sure that children (and adults) do not climb upon it. Since the observatory does contain moving parts, users must be careful to avoid injury. Keep your fingers away from the moving parts where they might become caught.

The shutters CAN BE DANGEROUS. Each shutter weighs about 40 lb., and slides on the slot edges. They are normally interlocked, and under control of the user. However, if they should not latch properly, or if they are separated for maintenance work, the shutters (especially the front shutter) can begin sliding with little warning. It is ESSENTIAL that care be used never to let the top or front shutter rest by itself at the top of the dome without proper anchoring (if the two are latched together as they normally are, there is no risk). To help prevent injury, you should consider installing a safety device on the front of the dome to limit unexpected downward movement of the front shutter.

To prevent high winds from damaging the dome, it is essential that the front shutter ALWAYS be fastened when the dome is not in use.

3. Special Assembly Instructions

This section contains special instructions that apply to several parts of the assembly and to special hardware issues. We have written these for the relatively unskilled assembler. However, even those who are skilled in carpentry or other mechanical assembly SHOULD read and follow these instructions, especially concerning leveling the structure.

Nomenclature

FIG 13

Parts of the PRO-DOME observatory have special names. These include the following.

- **Base Ring** – the ring that has the rotation rollers.
- **Foundation Ring** – the bottom most ring of the wall that bolts to your foundation. It will be the same as the base ring if you are not using extra wall rings.
- **Reverse Flange** - This is the curved topmost flange that is a part of the top flange of the base ring. The purpose is to hold the dome down in case of wind, and also to provide a drain for any water that might enter the dome.
- **Equatorial Flange** - This is the internal flange at the "base" of the dome quads, analogous to where the equator would be on the earth.
- **Front of Dome** - The dome is that portion of the observatory that rotates. The front of the dome is the location of the front shutter when closed.
- **Front of Observatory** - The observatory wall (or observatory building) is stationary and does not rotate. Usually, we define the entrance door to be the "front" of the observatory. These considerations are important when you install the foundation and walls, since you will want the door to be in the proper location relative to where you want to enter the observatory.

Locating Holes

In assembling the PRO-DOME, you will need to drill holes and insert bolts to hold the various pieces together. To aid in this process, we have created a document called "Bolt Hole Location Guide". This guide is at the back of this manual as an attachment, and is referenced section by section throughout the instructions.

In many cases, holes can be measured and drilled before assembly (referred to as "Guide" holes in the document. Much of the time these "Guide" holes are in smaller sections, which allows the work to be done in a more comfortable location (like a work bench in a warm garage). During assembly, if some of the holes do not quite line up, and if you are SURE no assembly mistake has been made, you can use your drill to "open up" the holes to accommodate a bolt. Hole sizes will be given in the instructions (most will be 1/4", 9/32", 3/8" or 5/16").

If you make a measurement error and drill the hole slightly off marks, just review how the pieces fit and function, and then use your best judgment for use of the bolt location: very few locations are all that critical. If you have questions call us for information or guidance. It is important, however, that the correct bolts be used in the correct order.

Failing this may cause interference, or may cause you to run out of the proper bolts later in the assembly process.

Drilling and Bolting

FIG 1

Many PRO-DOME parts are held together with carriage bolts or flat head bolts, 3/4 or 1 inch long. Carriage bolts have round tops, with a square shank that catches in the hole, preventing turning of the bolt. Flat head bolts are installed in a countersunk hole. We provide stainless steel carriage and flat head bolts, washers, and nuts to minimize corrosion.

In most cases, bolt holes are drilled before pieces are assembled. Drilling in fiberglass requires use of eye and skin protection, but otherwise presents no problems except that bits become dull after 50-100 holes. If a flat head screw is to be used, you will also need to use a "countersink" to create the sloping hole to accommodate the screw head. If available, use an 82 degree countersink, and cut the material just enough to recess the flat head, making it flush with the fiberglass surface.

Once the holes are drilled, assemble the pieces by installing the carriage bolt or screw in the proper direction (the instructions will tell you in each case). Be sure the bolt head is snug into the hole. Install a 1/4-inch washer and nut, and tighten. If the nut will not turn, check for fiberglass dust in the threads -- clean the nut and bolt and try again. Do not force the nut! A drop of oil may help as well.

If you drill a hole in the wrong location, either re-drill a new hole in the correct location, or, for small errors, enlarge the hole on the "nut end" piece, and install one or more large washers, or metal or wood plates, before installing the nut.

Here are some additional tips for drilling holes in fiberglass, or cutting it:

- Drill a pilot hole smaller than the final hole to keep the drill from wandering during the final drilling.
- A common twist drill will produce a triangular hole. In some cases, this can cause a problem. To prevent this, simply drill a hole a few 64ths smaller than the final hole, then finish drill with the desired size.
- Drilling fiberglass produces fine glass dust. If you leave it in the hole, the dust will get into screw threads and make nuts hard to turn. Clean the holes (rag on a screwdriver) and use a bit of oil on the screw to reduce the problem.
- A drilled hole will usually have a ragged edge. In most places, this is not a problem; however, you may want to know several tricks to prevent this. These include predrilling undersize holes, back up the fiberglass with a piece of scrap wood while drilling, drill partway through on one side then do the other side. You can also lightly countersink every hole after drilling.
- We often call for use of a countersink (makes a conical hole). If you don't have one, you can use a large bit (e.g. 1/2 inch bit on a 1/4 inch hole) to make the cut.

However, be careful not to go too deep. Also, note that the angle of the cone may not match very well the bolt that will go in it (usually 82 deg).

- Sometimes the gelcoat will chip when drilling or sawing. If this is a problem, there are tricks to use. These include putting masking tape on the gelcoat before drilling/cutting, use high speed cutting with low pressure, using fine toothed cutting blades, and drilling preliminary undersize holes.

Leveling the Foundation, Wall, and Base Rings

The more level the foundation is, the easier your overall installation will be. In any case, the top of your base ring or wall must be level (or at least planar). If the base ring is not level, the dome will not be supported uniformly on its rollers. This can cause a variety of problems not only with turning the dome, but also with the shutter operation as the shutter opening may be distorted. At least 1/4-inch accuracy in leveling is needed; however, 1/8 inch is even better.

While the "bottom line" is to achieve a level base ring, any wall built below the base ring should also be level and/or provide a means of leveling the base ring. Leveling techniques using shims or adjusting bolts are discussed below in the foundation section.

There are many ways to perform the leveling. Here are details on several of the best.

- If you have a transit or theodolite, you can use it.
- If you have a split image transit or eye held level, don't bother. It is not accurate enough and/or is too hard to use for this application.
- String levels are not sensitive enough.
- The human eye can see out-of-plane errors in the ring; however, it is very confusing to identify which portion is too high or low, and hard to estimate the amount. It is also hard to keep track of errors in the portions of the ring crossways to the line of sight, versus those more parallel.
- Carpenter levels, if sensitive, can be used, but will not do the job if simply moved around the circumference. See below.
- Water levels are far and away the easiest and best way to level the base ring or wall. They can be made or bought (about \$15), and are described below. (We once spent two frustrating hours with a carpenter level and split image transit and could not do better than 1/2 inch, but a water level did the job to 1/8 inch in ten minutes!)

Leveling with Carpenter Level

FIG 2

A two to four foot carpenter level can serve to level the structure. However, you will find that if you simply move it along the circumference, it is impossible to level the ring accurately. The problem is the subtle shifts of the bubble as you move around the ring.

If your pier is not yet in place, a much better method is to set up a support at the center of the dome, at a height equal to the top of the wall ring or the item to be leveled. Use a bar

from this center to the outer ring, and place the level on the bar. Now as you swing the bar around, you can track which parts of the ring are high or low relative to the center. It is easy then to adjust the wall ring to a level condition.

Leveling with Water Level

FIG 3

This is the best! A water level is made of two see-through containers, connected by a flexible, long tube, filled with colored water. (Hint - Use food coloring.) After adjusting the water levels, one container is set on a reference point (e.g., one spot on the ring) while the second one is moved to different points around the ring and the difference in elevation measured. The water level in the moveable container will rise (or fall) with the fall (or rise) of the level of the point you are measuring when compared to the reference point.

Commercial water levels read directly in inches, so it is easy to make accurate leveling corrections. Homemade water levels will work fine, so long as they don't leak. Water levels are tough to use in freezing weather. Add anti-freeze!

Making the Observatory Circular, and maybe Centered

While only the base ring **MUST** be accurately circular, it is highly desirable that all portions of the dome, including the walls, be circular. On the other hand, while aesthetically desirable, it is not necessary that the observatory be centered on some "magic" point, with all parts concentric (note that the telescope pier need not be at the center of the dome).

Identify the center of the observatory and mark it with a screw driven firmly into the foundation, or a small post sunk solidly into the ground. Mark the exact center of the screw or the post with a small nail driven into it but projecting 1/4 inch. You can now use this as the center for marking the foundation, your foundation bolt circle, etc.

The easiest way to start is to draw inner and outer diameters for your wall or base ring directly on the foundation. You will match the inner edge of the foundation ring bottom flange to the inner diameter that you drew. The outer diameter is there as a reference too, but use the inner mark because it is easier to keep in view.

To check the "centeredness" of successive (higher) wall rings, you will want a "center point" that is at the height of your wall. We will describe one easy method of providing this center.

FIG 2

As you build the observatory higher, you can use a plumb bob from beneath a tripod (surveyor or camera tripod) to establish a center at any height you want. If you have no tripod, nail a box together, or stack cinder blocks so that you can hang a plumb bob over your center point. With a little care, you should be able to perform the centering to about 1/8-inch. In either case, you can then use a tape measure to measure the radius to each point around the wall, so as to show that the wall is both circular and centered.

You will use several dimensions later in the assembly:

You will use several dimensions later in the assembly: Item	Average Outer Diameter (inches)	Circumference (inches)
Base Ring	119.00	373.85
DSR		*378.5
Dome	120.00 nom	377.00 nom

* Measured just below the top of the skirt

Stainless Steel Cable

Stainless steel cable is used in several parts of the observatory. In general, the cables we provide are longer than needed. In most cases, you can roll up the excess, tape it, and mount it out of the way. The cable is very strong, and difficult to cut — most wire cutters will not do the job. You can use steel cable cutters, or use the wire cutting portion of a Vise Grip© pliers, such as type 7WR (a wonderful tool — cheap imports are not good). You can also cut the cable using a cold chisel on a heavy steel plate. The cut end will be subject to fraying, and can easily cut the skin. To prevent this, gently unravel 1/4 in. of the cut end, and rinse it in acetone to remove the manufacturing oil. Ravel the end back, and put on a tiny drop of instant Crazy glue (don't touch it, or you will stick to it). This will protect the end against reasonable abuse.

4. Wall Construction.

Now we are ready to build the observatory! Even if your installation does not include a wall (other than the base ring), be sure to read the material on wall rings since wall ring and base ring assembly are very similar.

CAUTION

If the dome is to be installed on any support or wall more than three feet above the ground, or in a location with difficult outside access, we **STRONGLY** recommend that you preassemble the wall rings, base ring, dome, shutters, and all fittings on the ground. You can then assemble the dome in a convenient and safe situation. Once preassembled, it only takes 30-45 minutes to disassemble the parts. You can then re-assemble in place, knowing how the parts fit together, and with direct experience in handling the pieces.

The wall may be constructed using your own plans, or using wall rings supplied by Technical Innovations (or a combination of both!) Any wall must:

- be able to handle wind loads
- not twist as the dome is turned
- be water tight and resistant to the weather
- provide a solid, level support for the lower flange of the observatory base ring
- look good

If you are constructing a wall of your own design, we urge that you send a copy of your proposed wall design to Technical Innovations. We can review it, and may have suggestions or cautions that will make the wall easier to build, or otherwise help assure a successful installation.

Overview

In this chapter, you will begin actual construction. You will

- install the first ring on the foundation
- check circumference and make it circular
- bolt it to foundation
- assemble stubs, door sections
- assemble remaining rings, stubs, door, and hardware
- install rollers

We suggest you read the instructions carefully, and then perform the work in the order recommended. Re-check your work at each step. Now, let's go!

Wall/Base Ring & Semi-Door Assembly Preparation

Constructing all or part of a wall with PRO-DOME wall rings is very easy because every ring is the same size, material and design. The base ring differs from the wall rings by having a reverse upper flange, an access hole for aid in assembly, and holes cut into the upper flange for the rollers and electric drive plates. Rings can be stacked and bolted to the desired height, with the base ring at the top.

Each PRO-DOME wall ring (and base ring) is made of four equal length arcs of the circle. Three of the arcs are single piece, 90-degree sections. The fourth arc is actually in three sections — the molded semidoor section, a left hand stub section (left hand as seen from the outside of the wall), and a right hand stub section. These three sections (with spacing for the latches and hinge) are equal in length to a 90-degree arc. The door hinge will be on the right hand side of the door, as seen from the outside.

Before you begin assembly, it is wise to identify the parts for each ring and loosely set each ring together (but not stacked). You will notice that one end of each section is "stepped" inward (the "male" end) and this fits into the "female" (flush outside) end of the next section. The male end will aim to the LEFT as seen from the outside of the section.

Decide which wall ring will be the first (i.e., lowest) ring. Measure and mark the holes for your foundation bolts, [*Bolt Hole Drilling Guide #9*], on the lower flange of each part of this ring on the blue, rough, inside surface of the flange (don't drill them yet).

On all your wall/base ring sections OTHER than the bottom one, measure, mark and drill holes in the bottom flange -- use a 9/32" bit. [*Bolt Hole Drilling Guide #12*]

Then, in the female end of each piece, you will drill two holes -- use a 5/16" bit. Drill one at the top of the web (the vertical surface) 2" down, 1-1/8" from the end. Drill the other at the bottom of the web, 2" up, 1-1/8" from the end, [*Bolt Hole Drilling Guide #1 & #9*]. Later, you will use these holes as guides for drilling holes in the male ends for the bolts that hold the sections together to form the ring.

Before you proceed with the first ring assembly, read about alternative ways to stack the wall rings and door (see the next few pages). Decide which method you will use, because it affects how much of the first ring you will bolt down to your foundation structure. If you have more than 2 rings (base ring and one wall ring), we STRONGLY suggest using the method outlined in the “**Alternative Ways to Stack Wall Rings/Base ring**” section starting on page 22.

First Ring Assembly



To assemble your foundation (lowest) ring, select three full-length sections, a left stub, right stub, and molded door. Remember, this is the ring without holes drilled in the lower flange (and with the foundation hole locations simply marked).

Assemble the three 90 degree arcs and the right stub (not the door or left stub) on your foundation or on a reasonably level surface, with male ends pointing left. Insert each male end tightly into a female end, and set the door in place. Now place a 1/8 in. or 1/4 in. spacer (such as plastic, wood or metal) between the left-hand door jamb and the left hand door edge and hold the pieces together with a C-clamp. Clamp another spacer on the right hand side of the door section.

You will now check the circumference before drilling the final holes (in the male end of each section and left stub).

Measure the circumference (i.e., the distance around the ring about one inch down from the top) with a metal tape rule. Refer to the chart in Chapter 3 — your goal is a circumference of 373.8 inches (+/- 1/2 in.), corresponding to an average diameter of 119 inches. If the circumference is too small, pull the sections apart as necessary. If too large, push the last joint closer together (cut some of the female end if necessary). When you are satisfied, drill the final two holes using the previously drilled holes as a guide, in the three ring sections and stubs. [*Bolt Hole Drilling Guide #10*] Install 1-in. carriage bolts, washers, and nuts in the joint from the outside in. Do all five joints.

Note that while your wall ring has an average diameter of 119 inches, it is likely not to be an exact circle. That is, across one diameter it will be 118 while another may be 120 inches. Wall rings can easily be "nudged" two inches out of circular shape (and, conversely, are easy to nudge INTO circular shape). To gain a bit of experience, take a few minutes with the wall ring on a level surface, and measure -AND WRITE DOWN THE RESULTS- the diameter for at least six different "diameters" (directions) across the ring.

The easiest way to take diameter measurements is use a steel tape from the inside (blue) surface to the opposite blue side of the ring. If you swing the tape measure a few inches left and right, you will note the spot with the longest measurement, which is the diameter.

Try adjusting the ring to become circular to within about 1/2-in. maximum range (e.g., 118 3/4 to 119 1/4). This is an easy task, but only if you keep track of your work with a drawing!

Installing First Ring on Foundation

Now the job is to put the first completed wall ring on the foundation with the door section at the desired front (i.e., the entrance) of the observatory. If you are installing a rectangular or circular skirt, plan where the joints of the skirt will be placed (in most installations, a skirt is placed below the lowest ring).

If your PRO-DOME has a door (as most do), you should be aware that the sections of the door have the same height as the wall ring sections. Thus when the door is assembled, it will have the same height as the adjacent wall. If the wall is built on a flat surface, the lower edge of the door will scrape on the floor, and it will be hard to open. The solution is to raise the entire dome about ¼ in. with shims under the bottom ring, thus providing door clearance. Because most floors are not perfectly flat, some shimming will be needed in any case. After the observatory is built, you will then seal the underside of the ring with caulk or other filler.

Now, on with the show!

The trick now is to mount the ring onto the foundation, while assuring that it is circular, and getting holes in the lower flange to line up with your foundation bolts or anchors!

Lag Bolts and Anchors. If you are going to drill holes for lag bolts and anchors, you will already have marked the holes on the inside of the lower flange (but don't drill them yet). This process is a little complicated because you cannot drill into concrete without having the hole wander away from the mark. Proceed as follows.

A rectangular box containing the text "FIG 7".

- Place the ring on the foundation, and adjust it to be circular to within about 1/4 in. or better.
- Use a magic marker and draw the inner and outer outline of the base flange onto the foundation. Mark the azimuth locations around the ring on the foundation for the foundation holes. After marking the ring so that you can reinstall it in the same position, remove it.
- Mark and drill your anchor holes with a masonry bit. Install the anchors.
- You will likely find that the drill bit will have wandered, but not to worry. Draw a pair of 12-in. guidelines to the actual location of each anchor on the foundation.
- Reinstall and re-circularize (ugh, what a word) the ring. Using the guidelines and a straightedge, you can easily mark the wall ring flange for the exact hole locations to match the holes in the foundation.
- Remove the ring and drill your foundation bolt holes in the lower ring. Once the holes are drilled, again make sure the ring is circular, and install the bolts into your anchors.

A rectangular box containing the text "FIG 5".

Cast Foundation Bolts. If you are using foundation bolts already cast into the foundation, proceed as follows.

- Set the ring lightly on top of the foundation bolts. Make the ring circular, then mark the bolt locations on the underside of the wall ring flange.
- Drill your foundation bolt holes in the lower flange of the wall ring
- Install the wall ring on the foundation bolts as shown on the sketch.

Whichever fastening method is used, you must install large 1 1/2 to 2 in. washers under the bolt heads or nuts as shown, so that the wind and other forces will be spread out on the flanges. Use steel washers at of at least 1½-in. diameter.

NOTE: If you are using our suggestion in the next section to stack all door sections and all stub sections before assembling the wall, DO NOT install foundation bolts in the stubs just yet. Wait until the stacks are together.

ANOTHER NOTE: The bottom of the door must be at least 1/8 in. (1/4 in. is better) above the foundation to allow the door to swing open easily. When you install the first (lowest) wall ring, if the leveling process does not result in at least this much space under the door, you should insert the necessary shims around the ring. After assembly of the observatory, you will seal this space between the bottom ring and the foundation with caulk or other sealant.

Using your level, adjust the foundation nuts or insert shims to level the wall ring to an accuracy of at least 1/4-inch. Tighten all bolts.

You now have the first wall ring bolted to the foundation, with the door section clamped in place in the ring.

Alternative Ways to Stack Wall Rings/Base ring



This section will suggest how to assemble the stack of additional wall rings and final base ring.

One way is to build up the wall one ring at a time, the top being the base ring, and then assemble and fit the door. However, while this method gives good results for walls of just two rings, it can lead to substantial errors in construction for higher walls unless great care is used.

In our experience, a better approach for all wall heights is first to assemble all the door sections as a unit, and each stub as a unit. You will use a simple jig to assure accurate alignment of the vertical edges. The stubs and door can then be put in place, and the remaining wall rings fitted to them.

Lay out each remaining section according to left stub, right stub and door. Each stub and the door will be stacked with a “base” ring piece at the top of each. Locate and drill the guide holes in the bottom flange of each section, (remember that the one making up the bottom ring is attached to the foundation). [*Bolt Hole Drilling Guide #2 & #4*]

Prepare a flat and level working surface, such as a FLAT plywood sheet screwed to straight 2x4s. Clamp a straight piece of wood (a guide) onto the surface. Lay all the door sections together, blue side up, so that their edges butt against this guide. The goal is to end up with door edges that are as vertical as possible. Use another piece of wood to support the white surface of the curved door. Clamp the door sections together, and adjust as needed to make the door as straight as possible along both edges as well on the white (front) surface. Use a large square and straight edge (aluminum bar) to help.

Now, with the parts still clamped, fasten the door together, drill down through the pre-drilled holes in each lower flange into the adjacent flange, and install 1 in. carriage bolts. [*Bolt Hole Drilling Guide #5*]

After assembling the door, attach the hinge to what will be the right hand edge (as seen from outside). Adjust the hinge to be flush on the outside, and about 1/2-in. above the floor level. Drill only one screw hole (use a 7/32 bit) per door section (the rest will be added later).

Assemble the left and right stubs in the same way as the door. Again, your goal is to produce a vertical, straight door jamb. The resulting door and stub sections will still be somewhat flexible. [*Bolt Hole Drilling Guide #3*]

Now install the door and stub sections as the "front" of the observatory, fitting the stubs into the previously installed first (lowest) wall ring. Use a carpenter level to check that the door edges, door jambs, and wall surfaces are all vertical. Once you are sure the circumference is correct, you will bolt the bottom flange of the stubs to the foundation. You can now set the door aside. You will probably need to support the stubs in their vertical position -- use lengths of 2x4 with C-clamps or temporary bolts into the top of each stub to provide this support.

Proceed with wall construction by installing a ring at a time until you get to the base ring. It is best to assemble and stack all the rings, and install the door, hinge, and stubs BEFORE actually connecting the above/below rings together. When performing bolting, be sure to use a straight edge and vertical level to assure that the rings are directly above one another (the naked eye is easily fooled!).

Base Ring Installation

FIG 9B

The base ring is assembled just as were the wall rings. Because the base ring is where the rollers are mounted, it is particularly important that it be circular, level, and the correct circumference. Note that the base ring sections are not identical. They have roller holes, but also motor holes, an azimuth sensor hole and an access hole. Use the figure to assure that you locate the sections correctly. The motor holes and azimuth sensor holes are for optional equipment. Use the motor hole for rollers if you have no motors. Leave the azimuth hole empty if you are not using automation. The access hole will be used during assembly; it allows you to get at the top of the dome equatorial flange, and the underside of the DSR so that you can install the dome bolts.

FIG 22

Door and Hinge Completion

With all the wall and base rings assembled, remove the 2x4s that are supporting the stubs. Set the door (hinge attached) into position. Using clamps to hold the free flap of the hinge in place, mark two hinge screw locations onto the door jamb. Drill and install two screws and check that the door opens and closes without binding. Redrill as necessary. The left hand edge of the door may show a gap of as much as 1/2 in. at the top, but should fit well at the bottom. The top will be pulled closed by the latch to be installed.

Once satisfied with the hinge positioning, install a screw in every second hole in both sides of the hinge.

Latch Installation

FIG 22

The PRO-DOME door is locked with an upper latch and a lower latch. Both are controlled from the upper latch panel.

Upper Latch. The upper latch is shown in Figure 22, and consists of two latch plates, one to be mounted on the inside of the upper left of the door, and one on the upper left door jamb. The latch has two active components: a swing bar and a draw latch. When closing the door, the swing bar will also be closed, thus aligning the door and wall outer surface. The operator then hooks the draw latch on the door jamb onto the staple on the door, and closes the draw latch. This pulls the door edge towards the door jamb, closing the gap and securing the door.

Using the figure as a guide, mount the two latch plates as shown. Use two 1/4-20 FH screws and nuts on the upper flanges, and a single screw on each vertical flange. Countersink to achieve flush screw heads. The screw locations are not critical. To assure that the surfaces of the latches are in the same plane, we suggest you close the swing bar when installing the latch plates. [*Bolt Hole Drilling Guide #15*]

You can adjust the lateral position of the draw latch by loosening the screws holding its mounting plate and sliding it to either side.

Lower Latch. The lower latch is shown in Figure 22, and consists of a vertically mounted cable-operated slide bolt that engages a user provided hole in the foundation. You may choose to mount the slide bolt horizontally using a pulley to direct the control cable vertically. The latch is operated by TEE handle on the upper latch plate.

Mount the slide bolt as shown, using 10-32 flat head screws. [*Bolt Hole Drilling Guide #37*] Drill holes in the door section flanges so that you can feed the control cable up to the control arm on the backside of the upper latch plate. Loop the cable through the control arm, and use the clamp provided to obtain proper operation.

Roller Mounting

You have two kinds of rollers:

- three inch "support" rollers on which the dome rotates
- small, thin "side" rollers that keep the dome centered.

Support Rollers

FIG 11

The three inch support rollers are mounted in the base ring upper flange. Each full length section of the base ring has eight rollers, and each stub has three rollers. The door has one roller. Rollers can be installed before or after you have put the ring together. This can be done indoors on a work bench if more comfortable.

Most of the base ring roller holes are about three inches long to accommodate the rollers. There are also holes for optional rotation motors, an optional azimuth sensor and an access hole. If you do not have motors, install a roller in the middle of each motor drive opening. Leave the azimuth hole empty if you do not have automation. You will use the access hole during assembly of the dome on the dome support ring.

If you ordered the electric drive, we have provided only 29 rollers (vs. 31), so do not install rollers in these holes (even if you are deferring installation of the dome drive). See the dome drive instructions for instructions on mounting the dome drive pivot and spring anchor bolts at this time.

Check that the outer edge of each roller hole is smooth and flush with the inside of the base ring web (the web is the 12 inch high part of the ring). If it is not, use a file or rasp and smooth the fiberglass until it is flush. Use sandpaper to smooth the edges. Wear gloves and eye protection when drilling, cutting, or filing the fiberglass.

Use the template provided or transfer the template design in Fig. 11 to metal or cardboard, or use the dimensions in the figure to locate the roller axle locations. [*Bolt Hole Drilling Guide#6*] Drill a 5/16 hole, countersink and install a 2 1/4 inch flat head bolt from the outside through the roller. Install the flat washer next to the fiberglass, then the roller with its spacer in the axle, then the "thread guard" (hubcap) and a nut on the end of the bolt. Check that the wheel turns freely. If it does not, remove the wheel and find and remove the interfering material. Make sure the nut is not too tight.

Side Rollers

HOME-DOME/PRO-DOMEs are constructed with a Dome Support Ring (DSR). The DSR horizontal flange is the rolling surface for the dome, while the DSR skirt prevents the dome from moving sideways off the wall. Because of the DSR skirt clearance, the dome can move about 3/8 in. off center. Under some conditions, this movement can cause friction between the DSR skirt and the base ring of the dome, which in turn can

increase the force needed to turn the dome. The solution is to use side rollers to center the dome.

In general, you should space the 16 side rollers evenly around the base ring. [*Bolt Hole Drilling Guide#5*] To install, set a side roller on the base ring so that it projects about 1/8-3/16 in. outward from the base ring (use a 1/8 in. scrap against the outer surface as a template). Mark the center hole and drill a 13/64 hole. (Important -- use the correct size bit.) Screw in a self tapping screw (provided) so that the roller turns freely, but without wobble. If you wish, place a 1/4-20 nut as a "jam" nut on the underside of the self tapping screw.

Wall Bracing

If your wall is three or more feet high, you will find that when the door is open, you can move the upper edges of the door frame (jamb). This movement is normal, and causes no functional difficulty. However, if you prefer to stabilize the wall, we suggest using a length of 1/4 in. x 1 1/2 in. aluminum bar as a brace on the inside of the wall. The top end should reach about 2/3 of the height of the wall, and can be angled and bolted to the lower flange of a wall ring. The lower end of the bar should be anchored to the floor or foundation, at a distance of about 1/4 of the wall height. Be sure to paint the brace white so that it can be seen inside the observatory at night! An alternative stiffening process is to use expanding foam to fill the door cavities and the adjacent 18 in. of stubs.

This completes the wall and base ring installation. We advise that you NOT caulk the wall and base ring seams until the dome has been fully assembled and rotation checked. Note: Are you installing an Electric Dome Drive? If so, read those instructions — you may want to install some of the hardware (pivot and spring) now.

5. Shutter, Rear Cover, DSR Preparation

Overview

You will now prepare the shutters and rear cover. By doing so, the actual dome assembly will proceed quickly, and you will be able to get the dome covered and safe. In this chapter, we will prepare the

- Front Shutter, including glide strips, handle, electric shutter pulleys (if used), and lock
- Top Shutter, including the main bar latches and Shutter Restraint J-Guides
- Rear Cover, including pre drilling flange and shutter catcher holes and mounting the electric shutter motor (if used)
- DSR assembly and mounting

Front Shutter Preparation

FIG 16,16B

Bevel Check. Select the front shutter (of the three shutters, it is the middle width). Referring to the drawing, check that the rear top edge and latch receiving hole edges are beveled properly. If necessary, use a file to bevel the underside of the rear (top) edge and flanges so that it will ride up and over the rear cover. If necessary, bevel the latch receiving hole edges as shown, so that the shutter will disengage the latch. Sand any sharp edges of the shutter (since your hand may touch these at some time).

Handle Installation. Install inside and outside handles using the same pair of 1 in. bolts, with centerline 5 inches from the lower/front edge of the shutter. [*Bolt Hole Drilling Guide#19*]

Glide Strips. To reduce friction, the underside portions of the front shutter that slide on the slot edges have low friction strips of High Density Polyethylene (HDPE). These strips are attached using double backed adhesive tape. To assure good adhesion for the strips, you will need to clean the underside of the shutter adjacent to the flanges. Use GOOF-OFF, Fiberglass dewaxer, or other solvent or paint remover, preferably containing methylene chloride.

FIG 19

Four sections of strip are provided, each with a pre-bent end that fits around the end of the shutter (if the pre-bending does not fit the shutter, simply heat the pre-bent end with a hot air gun or propane torch and adjust the bend). You will fit two pieces of glide strip end-to-end on each side of the shutter, where it will slide on the slot edge. Trim the plain ends on a diagonal so that the two pieces are of about equal length and fit the length of the shutter. Clean the blue side, near the flange. To install the strips, start with the pre-bent end and fit it around the end of the shutter. Removing about 10 in. of wax paper at a time from the double back adhesive tape, press the strip firmly into place. Now apply the second strip that you have cut, start at the pre-bent end, etc.

DANGER

Once the low friction strips are in place, the front shutter will move very easily on the slot edge. As noted in Chapter 2, uncontrolled motion of the shutters can result in damage to the shutters or in serious personal injury. Always have the shutters under control when moving them. NEVER rest the front shutter alone at the top of the dome arc since it can begin sliding with no warning and slam down on the front or on a person.

This is not normally an issue, because the front and top shutter are normally safely latched except when they are toward the rear of the dome. You can install the shutter safety device described in Fig 18 or a similar device to limit uncontrolled shutter movement.



FIG 18

General Next Steps. If not installing the deadbolt lock or an electric shutter, install two 1 in. carriage bolts 7 1/2 inches from the front edge, 2 inches inside the side flanges (measured on the outside of the shutter). These bolts should project inside, and will rest against the top edge of the rear cover when the front shutter is on the dome in the retracted position. Without these bolts, in the open position the handle would otherwise rest against the rear cover edge. This would pinch your fingers!

Finally, install the vinyl "push on edge trim" piece to provide a softer leading edge for the end of the front shutter. Push on, or use light hammer blows, as needed. If your head bumps the edge of the partially open shutter, you will appreciate this (we did, the second time).

Security and Locks

The PRO-DOME is designed so that the closed and latched dome can be secured simply by interlocking only one item: the front (lower) edge of the front shutter. If a big storm is predicted you should use some kind of securing device (bolts or padlocks) to prevent wind from lifting the front shutter when the observatory is closed. That is, both flanges of the front shutter should be held to the slot edge. Failure to install and use a locking device of some type may result in damage to your dome in event of a wind storm.

The simplest method is to drill a hole in each shutter flange through the slot edge and insert the shutter lynch pins, or 1/4 in. diameter bolts, or a 1/4 in. diameter rod all the way through the four holes.

Top Shutter Preparation and Latches

You will now install the latches and shutter restraint system cable guides on the top shutter.

FIG 16B

Latch Installation. The short latch will go on the rear of the shutter and engage the hole in the rear cover, while the longer latch is on the front of the top shutter and engages the hole in the front shutter. The installation of each latch follows the same steps: we will describe the front latch installation. [*Bolt Hole Drilling Guide#18*]

Inspect the outside of the top shutter carefully; you will see scribe marks in a line about 7 3/4 inches from each end of the shutter with five marks for the **front**, and four marks for the **rear** latch. Drill 5/16 holes and install each latch to the blue side of the shutter with 3/4 in. stainless steel carriage bolts, with the "points" of the latches facing the center of the shutter. Note the countersunk holes for the nuts and washers.

Top Shutter Restraint System J-Guides

FIG 24

The Shutter Restraint System is a cable and spring system that applies a calibrated radially-inward force to the top shutter to prevent wind from lifting the top shutter or the adjacent end of the front shutter. This system allows the observatory to be operated under higher wind conditions because it assures the engagement of the top shutter latches when closing the shutter.

You will now install the J-guides on the top shutter. With reference to the figure, each flange of the top shutter has J-shaped guides through which will pass a 1/16 in. stainless steel cable. The cable will connect to a bracket at the rear of the dome and to a special spring mounted on a post toward the front of the dome.

The J-Guides install with the cable hole outside the shutter flange. On each flange, install a guide about four inches from each end. Install the remaining guides evenly spaced between them. In all cases, the loop of the guide should be below the flange. Mark, drill, countersink, and install the guides using 10-32x3/4 flat head screws from the **INSIDE**, with locknuts on the **OUTSIDE**. [*Bolt Hole Drilling Guide#17*]

Rear Cover Preparation

FIG 16, 16B

The rear cover is the narrowest of the three and has a downward lip at the top (front) end. The rear cover fills in the circle at the rear of the dome, and stabilizes the two quadrant pairs near the zenith.

Referring to the drawing, check that the bevels are correct in the latch receiving hole in the rear cover, and on the top (front) edges of the rear cover. If not, use a file or rasp to bevel the edges as necessary. Sand the remaining edges if necessary.

Measure and marks the locations for the guide holes on the flanges of the rear cover and drill 1/4 in holes. [*Bolt Hole Drilling Guide#22*] There are seven holes on each flange. Then countersink all holes for flat head bolts.

Electric Shutter

If you are using an electric shutter, you should install the shutter motor onto the rear cover at this time (it is easier to work on the level, rather than overhead, later). Refer to the electric shutter instructions for dimensions and locations.

Shutter Catchers

Mark and drill 9/32 holes for the two shutter catcher brackets. They go on the lower right and lower left corners of the rear cover, as shown in the two drawings. [*Bolt Hole Drilling Guide#21*] The tab on each metal shutter catcher (has a small hole in it) sticks out beyond the edge of the rear cover. (The purpose of the triangular “ramp” on the catcher is to guide the shutter to the outer edge of the catcher during the opening process.)

FIG 14, 24

You can install the shutter catchers now with 1-inch carriage bolts, or do it later after you fasten the rear cover to the dome halves.

FIG 12

Dome Support Ring (DSR)

Before installing the DSR on the base ring, use a stiff brush to remove all easily removable grit from the underside of the DSR. Compare the beveled edges to the drawing, and if you note any corrections to be done, do them now with a file or grinder (please wear gloves and eye protection.) If some of the DSR section ends are not square, trim them at this time.

Pick out the DSR parts to use for the front (DSR section with swing-out), and pick DSR sections to be used on the rear and sides and place them on the base ring rollers. Assemble the DSR sections on to the base ring, and make sure the DSR sections ride around the dome without binding.

Tape a dozen or more pieces of 1/4 in. thick material (such as masonite or plywood) around the outside of the base ring, up between the base ring and the DSR. This will establish the DSR gap and assure a round DSR (because the base ring is round).

Using 24 in. of duct tape on the outside of each DSR joint, tape the DSR sections end to end so that the ends of the horizontal flanges are butted together with minimal, but equal gaps. Check that the circumference near the top of the DSR is close to that given in the table. Once adjusted, drill a single hole through each DSR overlap lip and from the inside install a 6-32x1 in. screw and nut to join the DSR sections together. The screws can be removed later. [*Bolt Hole Drilling Guide#16*]

Remove the 1/4 shims, and rotate the DSR so that front section (swingout) is at the front of the observatory. Find the center of the FRONT DSR section. Use a pencil to mark 17 and 18 in. on each side of the center: these will be rough guides for the location of the front slot edges of the quads.

Tape the DSR so that it cannot rotate. You now have the DSR ready to receive the dome.

6. Dome Construction

The wall and base rings are done as well as all the shutter preparation: now comes the real fun. But first, here are some words of caution:

- Two people make the job of holding pieces in place much easier.
- Be sure to follow the sequence of assembly given here. Failure to do so may allow construction errors to accumulate, and cause rotation problems.
- Do not do this job on a windy day: fiberglass quadrants make great sails. They will not look pretty flying into something or someone.
- At various times during assembly, you may have quadrants resting without bolts on the dome support ring. We urge that you use jigs, clamps, or duct tape or other means to prevent a quadrant falling off the wall and becoming damaged.
- If the dome is to be installed on a wall more than three feet high, or in a place with difficult outside access, we **STRONGLY** recommend that you preassemble the dome and base ring on the ground. You can then partially disassemble it, and then reassemble the dome in the final location, knowing how the parts fit together, and with direct experience with handling the pieces.

FIG 10,10B

Overview of the Action

Here is a preview the coming action: You will

- pre-drill the holes in the quadrants
- assemble the two dome halves, and install electric shutter channels, if used
- install the quads and rear cover on the DSR, with braces, tape, and bolts
- adjust the dome, then sequentially finish bolting the quadrants to the DSR.
- install and test shutters
- complete installation of locking system

FIG 13

This portion of the project normally takes less than a day, and will result in a secure dome that is ready to stand up to the weather.

Dome Quad Assembly

The dome is made of two slightly different dome quadrants. We refer to these as the right and left, as viewed from the front of the dome. The left front quadrant is the same design as the right rear, and vice versa.

Pick out the right and left front quads. Refer to the drawing to identify what we call the equatorial (lower) flange, the slot edge, and the Greenwich flange (inner flange joining the two quadrants). Measure and mark the guide hole locations on the equatorial flanges [*Bolt Hole Drilling Guide#23-24*] (also refer to the drawing for hole locations) and drill 9/32 holes. Measure and mark the guide hole locations on the Greenwich (narrow inner) flanges and pre-drill 3/8 in. holes [*Bolt Hole Drilling Guide#25-26*]

Pick out the right and left rear quads. Refer to the drawing to identify what we call the equatorial (lower) flange. Measure and mark the guide hole locations on the equatorial flanges [*Bolt Hole Drilling Guide#27-28*] (also refer to the drawing for hole locations) and drill 9/32 holes.

Place the right and left quadrants together on a reasonably level surface (not yet on the DSR!), with a 2x4 under the Greenwich flange joint. Clamp and adjust the positions of the quadrants so that BOTH the equatorial and slot edges are aligned, and the outer dome surfaces meet as smoothly as possible at the Greenwich flange. Using the previously drilled holes as guides, drill 3/8 holes in the Greenwich flange. Install 1 in. carriage bolts through the two Greenwich flanges and tighten. [*Bolt Hole Drilling Guide#29-30*]

Once bolted together, the two quadrants will stand together without support. Prepare the second pair of quads in the same manner. If using the Electric Shutter, install the cable pulley assemblies now, when the slot edge is easy to reach. See ES instructions for details. Also drilling the wind restraint cable post holes at this stage will make that installation much easier later on. [*Bolt Hole Drilling Guide#33-34*]

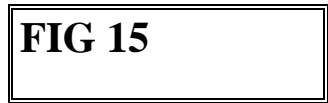

Check that the DSR is ready to receive the quadrants. With one or two additional helpers, lift the quadrant pair onto the DSR. With the aid of a second person, carefully move the quadrant pair around the DSR until the front quadrant slot edge is in position next to the previously drawn 17 inch mark. With the second person holding the dome onto the DSR, use duct tape to hold the dome quads onto the DSR (tape around the quad edge and in over the reverse flange).

You will notice that the outer surface of the dome at the Greenwich flange may be inward from the DSR several inches. This is normal: this will be adjusted after you install the rear cover when you install the equatorial flange bolts.

Install the second pair of quads in the same manner.

Spacers. You will be placing the rear cover on the rear of the dome and bolting it in place. This will "fix" the width of the rear of the slot. But first, to set the front slot opening, and to keep the dome halves in place as you work with the rear cover, install two pieces of wood (e.g., 2x2) as spacers between the slot edges, one at the front of the dome 12 in. up from the DSR, and one about 18 in. in front of the zenith. Make your spacers the right length to produce a front slot opening of 36.25 in. measured at the outside (white) surfaces. Install by drilling a small hole in each slot edge, and installing a 2 in. wood screw into the spacer.

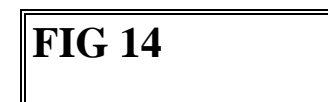

Rear Cover

Install the rear cover so that it overlaps the rear slot edges, with the lower edge of the rear cover approximately 1 inch below the lowest part of the slot edge. Make sure the right and left sides are equal. Be sure the rear cover is fully seated against the slot edge, and is not "outward", especially toward the top of the dome. You may

want to use a prop or C-clamps to hold it in position. Using the previously drilled holes in the rear cover as guides, drill 9/32 in. holes into the rear slot edge. Start at the bottom of the rear cover. Drill both left and right holes, and install 1 1/2 in. flat head bolts. Then work upwards, doing the next pair of left and right holes, and so on. An assistant inside the dome may need to push the slot edges outward against the insides of the rear cover flanges. [*Bolt Hole Drilling Guide#31-32*]

When the rear cover is bolted on, you have the two dome halves joined together, resting on the DSR with duct tape holding the quads in position, and with wood braces in front. You can now remove the duct tape: it has done its job.

You will now install the equatorial flange/DSR bolts while assuring that:

- the slot opening is 36.25 in. (outside)
- the dome is centered on the DSR

Check the front slot opening. If it is not 36.25 in. outside, adjust the dome halves or spacers as needed.

Check each of the slot edge tabs where they overhang the DSR. Each slot edge should be within 1/4 in. of the DSR and must be equal for the left and right dome halves, and front and rear. Adjust the dome halves as needed (just push and pull).

The exterior of the dome will overhang the DSR by about 1/4 inch on the front and back, and be flush on the sides. If the dome overhangs more on one side than the other, and the DSR sections have not disconnected, simply move the dome over (you can use more tape to hold in position, if you like).

Now you will install the bolts in the equatorial flanges, working from the front to the rear.

Drilling Process Overview. You will use the previously drilled holes in the equatorial flanges as a guide for drilling 1/4 in. holes **down** through the DSR flange. You will rotate the DSR/dome so that each hole in succession is above the access hole. At each location, drill the hole, you will countersink the DSR from beneath, and install a 3/4 flat head bolt upwards. Be sure to use eye protection! Be careful when turning the dome to keep the dome securely fastened on the DSR! Hint: It is efficient to work with two drills, one for drill bit, one for countersink.



With the dome centered, drill and install the 1R and 1L bolts first, followed by the 10R and 10L bolts. Recheck the dome. If everything is OK, install the remaining bolts. Hint: if you want to make an even nicer job, at each bolt location, work with a second person outside the dome to adjust the dome and DSR closer to a symmetric overhang all the way around before each hole is drilled. Remember the comments given above concerning bending the dome near the Greenwich flange. [*Bolt Hole Drilling Guide#35*]

You may now remove the braces from the slot opening.

When you are done, remove the DSR lip bolts (or leave them in if they do not interfere with rotation.) Turn the dome! If you assembled the dome correctly, it will turn easily. But don't panic if it doesn't. See Chapter 8 for how to investigate and fix any problems. Note: fix any rotation problems BEFORE continuing. And don't caulk the base ring, wall joints, or dome equatorial flange until you have a smoothly operating dome.

Shutter Installation and Initial Operation

Install the shutter catchers onto the rear cover using the previously drilled holes using 1 in. carriage bolts.

Place the front shutter on the rear of the dome so that the handle is up and toward the front, and the flanges straddle the rear cover. The shutter will not rest on the shutter catcher, because the handle will rest against the top edge of the rear cover.

Install the top shutter (long latch to the front) so that it rests in the shutter catcher, and straddles the front shutter.

You will now close, then open the dome. Enter the observatory, and grasp either handle of the front shutter. Pull the shutter toward the front (i.e., up and over). It should slide easily, though you will note its weight. As it moves past the top of the dome, the front latch of the top shutter will drop into the hole in the front shutter, so that you will begin moving both front and top shutters together. As the front latch and hole become visible on the underside of the front shutter, visually check that the latch is **fully seated**. Assuming that it is, still keeping your hand on the handle, continue pulling forward and down. The rear latch on the top cover will engage the rear cover, and the shutters will lock into the closed position.

Note: if the front latch does not **fully** engage, restore the shutters to the back of the dome, and retry. If the latch does not seat properly on the second try, **DO NOT** attempt to use the shutters until you have found and corrected the problem (See Chapter 8).

To open the shutters, simply slide the front shutter up and back. Both the top and front shutter will move back. As the front latch rides over the rear cover, it will partially unlatch, completing unlatching when the top shutter rests on the shutter catcher. Continue moving the front shutter back until it is seated. **DO NOT** let go the front shutter until it is fully opened and in the rear, as it will slide uncontrolled to the back where it may be damaged.

FIG 16B

As you open the shutter the first few times after the observatory is constructed, you should make several observations as you slide the shutter up the first foot or so:

- watch that the top shutter moves back as the front shutter is slid upward
- look up inside to check that the rear latch has disengaged from the rear cover
- look up inside to check that the front latch is still partially engaged (i.e., still in the hole)

Your last step is to check that the latches fully seat when the dome is closed and front shutter locked down (so that the wind cannot lift either shutter). Go inside the dome, and pull the shutters closed. Check that both latches dropped into their receiving holes and that they fully lock the rear cover and front shutter. If not (for example, if the inside handle is preventing full closure), be sure to correct the problem before continuing. Shutters have never blown off a PRO-DOME that is properly secured!

We strongly recommend that as soon as you have verified full shutter latching, you drill holes in the shutter and flange as discussed below, and use spare bolts or the lynch pins from your kit to secure the front shutter. The wind will blow tonight!

Constructed according to these directions, the past zenith opening of the dome shutter will be about 16 in., and the front shutter when closed will extend about 2 in. below the end of the dome slot edge.

Notice: Our warranty does NOT include consequential damages for damage or theft arising from failure of the lock to prevent entry into the dome. Locking and alarm systems can and do increase the difficulty of unauthorized entry; however, be aware that no system is perfectly secure!

7. Finish Work

Overview of Finish Work

There is only a bit of finish work left. You will need to complete or install a number of items that help protect the observatory and make it safe and enjoyable to use. These items include

- finish installation of the shutter restraint system
- install DSR safety brackets
- install the rear soffit
- finish installation of the electric shutter (if used)
- finish installation of the electric dome rotation (if used)
- install a summary instruction sheet.

Shutter Restraint System

FIG 24

The Shutter Restraint System is a cable and spring system that applies a calibrated radially-inward force to the top shutter to prevent wind from lifting the top shutter or the adjacent end of the front shutter. This system allows the observatory to be operated under higher wind conditions because it assures the engagement of the top shutter latches when closing the shutter. Of course, it also prevents the wind from blowing the shutter off the dome when the shutter is open. If this system is not installed, the Pro-Dome should NOT be operated if the wind is more than about 15 mph, a very light breeze. With the system installed, the dome is safe to operate to about 30 mph, a very stiff wind. Note that this system does not affect the wind strength of the properly closed observatory--that is a function of the strength and design of the fiberglass, latches, and front shutter hold-down. However, it will improve the resistance to shutter lift off if the shutters are not fully and properly latched.

Description of Operation As you see in the drawing, J-shaped brackets are bolted to the white side of both flanges of the top shutter. A cable passes through the holes in these brackets. Each cable is anchored to a shutter catcher bracket at the rear of the dome, and to a special spring that is mounted on a post toward the front of the dome.

When the shutters are in the rear, the cable will act as a restraining force inward on the top shutter, so that the wind cannot lift it away from the dome. The spring is designed so that it has only a limited travel, so even a high wind cannot do more than lift the shutter an inch or so.

You will adjust the cable tension when the shutter is closed. The spring and cable will be at low tension, virtually zero. Here is the reason: When you are opening the shutter, the front and top shutter move backwards until the rear latch leaves its latch receiving hole. This raises the rear of the top shutter. Again, when the front latch disengages from its hole in the front shutter, the top shutter raises up. You want no tension on the cable at any point of the opening or closing because it might prevent one of the latches from coming out of its hole.

At the rear of the dome, where the cable is outside the top shutter J-guides, small cable posts mounted on the dome keep the cable from sliding across the dome surface.

You have already installed the J-guides on the Top Shutter. You will now install the remaining items.

Spring Post. If the holes for the spring and cable posts were not drilled during the assembly of the dome quadrants, do so now. [*Bolt Hole Drilling Guide#33-34*] The front most hole on each dome half will be for the Spring Post. Install the spring post and spring using the carriage bolt supplied. Repeat for the other side of the dome.

Rear Cable Bracket. The rear cable bracket is a part of the shutter catcher already installed. The bracket tab has a small hole and projects out from the rear cover.

Cable Installation. One end of the cable attaches to the spring, the other end to the rear bracket. One end of the cable has a permanent termination loop, the other end is bare where you will use a split bolt as a cable clamp. In most installations, the permanent loop is attached to the spring, and the cable clamp is at the rear where it is more convenient to adjust the cable tension. Assuming the clamp will be on the rear, feed the free end of the cable through the spring then through the loop.

With the top shutter back in the shutter catcher, feed the free end of the cable through the J-guides and attach the end to the rear bracket with the cable clamp. You will readjust/tighten it later.

Cable Guide Post. The cable posts prevent the cable from sliding across the dome (this is primarily an aesthetic issue). Install cable posts in each of the remaining holes on each side of the dome. These posts follow a line outside the spring post and the top shutter. Thus, the cable will drop onto the dome inside the cable post, which keeps the cable from moving more than 3/4 in. over.

Cable Tension Adjustment. With the shutters **closed**, adjust the cable tensions so that the cables are LIMP, i.e., NO tension. Tighten the cable clamps tightly and test the system by operating the shutter. You should see a slight spring tension as the shutter opens and the latches leave the receiving holes. You should see no more than a very slight spring tension as the shutter opens and the latches leave the receiving holes. You should notice no increase in the force required to operate the shutters compared to no wind restraints. If you see a significant increase in shutter force, relieve the tensions slightly and retry.

Notice: This Shutter Restraint System is somewhat sensitive to errors in the shapes of latches. If the shutters do not want to unlatch, please see Chapter 8.

DSR Swingout Safety Brackets.

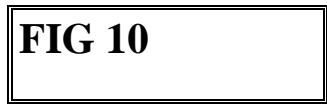

The DSR Swingout Safety Brackets hold the DSR swingout close to the top of the semidoor as the semidoor is opened or closed. Besides simplifying semidoor operation, the brackets also prevent the dome from turning unless the DSR swingout is closed.

Bolt these brackets onto the semidoor, about 2 in. from the left and right edges of the door. The brackets should project above the lower edge of the DSR about 1/2-3/4 in. The dome should turn without interference with the brackets. [*Bolt Hole Drilling Guide#36*]

The instructions, plus a warning label on the DSR swingout, state that the dome must NOT be turned while the DSR swingout is open. If the dome is turned with the door closed but the DSR open, the dome may fall down around the wall (if this happens, you must get a group of people to help lift the dome back onto the wall!)

Soffit

FIG 17

The soffit is a crescent shaped fiberglass part that covers the gap inside the dome between the rear cover and the DSR. Installation is optional. If you choose to install it, use two bolts to attach it to the rear cover. It may rest on the DSR, or you may use spare flat head screws through the DSR to hold it in position. [*Bolt Hole Drilling Guide#38*]

Anti Rotation Linch Pins (or Bolts)

Although optional, anti-rotation bolts are desirable for preventing rotation when you are NOT observing and for doubly assuring that severe wind storms do not damage the dome. We suggest using 1/4 or 3/8 in. diameter carriage or other bolts, washers, wing nuts, or other devices convenient for you. You should drill four holes down through the equatorial flange, DSR, and base ring. You can then insert long bolts to prevent rotation when your dome is not in use. During windy periods, especially when you know a severe wind storm is coming, it is desirable that you place nuts on these bolts and tighten them to make sure the wind cannot lift the dome off the base ring. [*Bolt Hole Drilling Guide#39*]

Caulking

If you are satisfied with the dome assembly, it is time to caulk the joints.

If it is too cold or wet to caulk, you may use vinyl tape from a hardware store and apply it to the joints, or you can just leave the joints uncovered (normally VERY little rain will get in). Do not use duct or electrical tape, since these leave sticky residues that are difficult to clean. Tape should be removed as soon as the weather improves. Use tape or low quality caulk if you plan to disassemble the dome in a short time (good caulk is harder to remove!).

If the dome has been exposed to rain, it almost certainly has water between some of the flanges: it can stay there for weeks! Before caulking, the water should be removed or

else the caulk will not make a good bond. You can wait, and verify dryness by looking into the joints or inserting a paper strip. But an easier way to get the water out is to use a hair dryer or compressed air or similar means to blow out the water.

Our experience is that simply injecting caulk into the (dry) exterior seams from the outside forms a completely effective seal. We provide clear silicon caulk (the clear ends up looking better than white). With the seams clean and dry, inject a smooth bead. We recommend that you not try to smooth the bead with your finger or other tool because then the silicon caulk tends not to form a smooth surface. Extend the caulk down along the skirt side joints on the DSR. Check that you have applied caulk on the joints between the quadrants (Greenwich Flange), including the joint as it extends up and under the shutter flanges at the top of the dome.

If you want to inject caulk deep into the seams, you can do so by loosening the flange bolts and installing small wedges. Inject caulk into the opening, being careful not to overdo it at the points where the DSR sections abut. You do not want caulk to ooze down into the roller area. Remove the wedges, and tighten the bolts.

If there is a gap between the bottom of the wall and the foundation, now is the time to fill it. We recommend expanding foam, which you can inject into the gap. It will ooze out inside and out, but after it hardens, you can cut off the ooze with a sharp knife. Paint the outside with latex paint so the sun won't cause deterioration.

Instruction Sheet

Elsewhere in this manual we have provided a summary of the use and maintenance instructions that apply to your observatory. We recommend that you post a copy in the observatory. If a user did not participate in constructing the dome, be sure to go over the instructions so that the observatory AND the user are protected!

8. Problem Solving

This section describes some problems that may occur and how to solve them. Most problems are easily solved with a careful, step by step approach. In the event that some parts need to be modified, or if portions of the dome must be disassembled and then reassembled, don't despair: these activities are easy to carry out. You will find that fiberglass is very forgiving of errors, and that fixing problems is usually very easy, once the problem is understood. If you find that you need to, call Technical Innovations and we will try to help.

Dome Rotation Problems

One possible problem at this point is that the dome does not turn easily, i.e., it turns easily at some points of the circle, and not at others, or it may turn in one direction and not the other. A systematic look will generally locate the problem.

First, check that all the blocks are removed, and that there is no foreign material (tape, wood scraps, etc.) between the DSR and the base ring. A bolt or nut under the DSR can make horrible noises at particular rotation points, and also resist rotation. Check that the DSR lip screws have been removed (or are not touching the base ring). Check that the rollers are all clean. Check that nothing is catching on a sharp edge (this will normally show up as a sudden stoppage of the rotation). If this is the case, find the offending spot and bevel or modify it. If you think the problem is under the DSR (e.g. a lost bolt), see the section "**Base Ring Service**" below for how to inspect that area safely.

If nothing is catching on an edge, i.e., the dome simply is much harder to turn at some points, the problem is likely to be binding of the DSR against the base ring. This can have several causes:

- the Base Ring was made too large
- the DSR was made too small
- Base Ring and DSR are out of round.

FIG 21

Check your base ring and DSR circumference measurements. (Compare to the chart in Chapter 3.) The DSR circumference should be at least 2.5 in. greater than the Base Ring, giving a DSR diameter at least 0.8 in. greater than the base ring. If the DSR to Base ring diameter difference is too large, (Case 3 in figure), binding will not occur but you will have substantial side to side movement as you turn the dome. If the DSR to base ring diameter is too small (Case 4), binding will occur.

Case 1 shows correct circumferences, with the dome centered on the base ring. As you turn the dome, you can push the dome off center (Case 2), given the DSR-base ring gap. This is normal.

Now, suppose the circumferences are OK, but the base ring and/or DSR are out of round. If centered, Case 5 shows that the gap may be uniform around the dome. But if you turn the dome 90 deg. (Case 6), you will see a different pattern of gap measurements. If you suspect this case, carefully take several sets of measurements, pushing the dome in both directions, and compare the results to determine exactly what is happening.

The most common cause of the problem was that the base ring was not circular during initial assembly (e.g., was forced onto improperly located foundation bolts). If the base ring was out of round, this would then cause the DSR to assume an out of round shape when bolted to the dome quadrants.

In either case, examine the situation carefully, make careful measurements, and think out carefully what is happening before making changes. If necessary, set up a good center point so that you can measure the "radius" of the Base Ring and DSR at different points on the circumference, and plot the results. Proceed step by step, rather than "just trying things". Try loosening the bolts holding the item (e.g. one of the DSR sections) to its improper shape, modify the shape (use people power, twisted ropes, duct tape, clamps, or other means), drill new holes, and install and tighten new bolts. Don't worry about making extra holes in the DSR or other parts (the extra holes won't show, and the parts are all sufficiently strong to accommodate the extra holes).

Shutter Engagement Problems

FIG 16

Shutter or latch engaging problems are nearly always caused by the edge of one item catching the edge of another. To solve, simply examine closely the location of each shutter as you have the problem, and identify the offending points. Fix it by beveling or adjusting the interfering edge properly. If the problem is a cavity (rather than a projection), fill the cavity with epoxy or polyester resin (or BONDOL from an Auto store) and file to obtain the desired shape.

If the latches of the shutters do not properly engage, do NOT use the dome until the problem is corrected.

Shutter Dis-engagement Problems

When the shutter is opened the first few times after the observatory is constructed, you should make several observations as the shutter moves up the first foot:

- watch that the top shutter moves back as the front shutter is slid upward
- look up inside to check that the rear latch has disengaged
- look up inside to check that the front latch is still partially engaged (i.e., still in the hole)

When opening, if the front latch disengages while the rear latch remains engaged (the opposite of what should happen), then when the rear of the front shutter reaches the latch it will force a disengagement. The top shutter will then slide to the back OUT OF CONTROL and will usually break the shutter catchers. This can damage the shutter, and is dangerous and must be corrected.

The cause of this behavior may be one or both of the following:

- some condition at the rear latch or hole prevents easy disengagement of the rear latch
- some condition allows the front latch to disengage too easily.

The top shutter rear latch should disengage very easily as the top shutter is pushed back. Difficulty can be caused by:

- The rear latch may be excessively rounded at the ends of the rear face with a perpendicular bevel ("A" in figure). Because the rear edge of the hole is triangular, the ends of the latch will initially contact the rear of the hole, and a perpendicular face will not slide up out over the edge. Correction is to cut off the ends, or modify the bevel from perpendicular to sloped (as is the remainder of the rear face)
- The rear of the rear latch hole may be beveled too sharply ("B" in drawing). This can cause grooves or cuts in the rear face of the latch which worsen the problem. Correction is to sand the face to less than 45 deg with smooth edges. If the rear face of the latch is grooved, sand or shave it smooth.
- The front of the hole may be beveled too sharply, causing the latch to jam in place ("C" in drawing). Sand the front of the hole to a more vertical face, and smooth the edges.

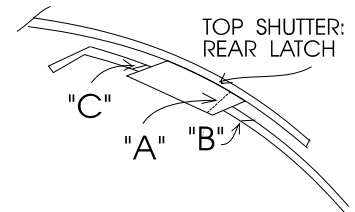

The front latch should NOT disengage until the front latch passes over the down lip of the rear cover and the rear of the top shutter has reached the shutter catchers. Too easy disengagement can be caused by lack of vertical bevel on front face of latch. Correction is to create a bevel about 1/4 in. high (sand, plane, or cut).

Note, sometimes there may be excessive force required to disengage the front latch even when they are back in the correct position. This may be caused by warped shutters, a front shutter glide that has come loose, excessive electric shutter tension, or other problems that lift the front of the top shutter and/or the rear of the front shutter away from the dome. The cure may be to reduce an excessive front latch vertical bevel, or to make vertical the front edge of the front hole.

Shutter Blow-off

With the shutter restraint system in place, it is virtually impossible for the shutters to blow off. If the top and/or front shutter should blow off your dome, it is almost always that the latches were not fully engaged holding the top shutter to the rear cover and front shutter, or that the front shutter was not fastened to the front slot edges. Please review the shutter installation instructions, and recheck your latches and locking system. Never use ropes or bungee cords to hold the shutters in place.

Base Ring Service

If you identify a problem that requires you to work under the DSR, you can do this WITHOUT disassembling the dome from the DSR. Simply turn the dome to the position needed, and open the DSR swingout, thus allowing access to the base ring beneath. However, remember, UNDER NO CIRCUMSTANCES should you turn the dome unless the DSR is closed and locked. Failure to follow this rule may cause the dome to fall off the wall.

9. Use and Care of your PRO-DOME

Your PRO-DOME should give you many years of faithful service. Feel free to modify it, drill holes in it, and generally add your own personal touches to it. The walls are strong, so you can use any fastening means (including fiberglass) to add desks, benches, etc. as you desire.

Use the dome, but exercise reasonable care: it is NOT a toy. Don't let adults or children on top of the dome. And keep flames away: remember, fiberglass is flammable. If you use a heater, be careful to keep it away from contact with the fiberglass.

Your closed and locked observatory is designed to withstand the full range of normal adverse weather conditions, including extremely high winds. However, it is not designed for occupied use under high wind conditions. It is not possible to place a specific limit on the wind velocity that is acceptable, although most users find that winds above about 30-35 mph are not comfortable. If you wish to use the dome under higher wind velocities, you should contact us for additional guidance and recommendations.

Although your dome is very weather tight, be sure to cover your telescope with a sheet of plastic when not in use. If the air temperature drops so that the dew point is below the dome temperature, condensation can form, and drip from the top of the dome. This is rarely a problem except for domes attached to a house or other source of water vapor (in that case, you must have double doors or other means of keeping the water vapor out of the dome). If condensation is a problem, try a small heater, dehumidifier, or 100-200 watt lamp near the center of the dome and call us for additional help.

Your PRO-DOME requires very little care. Overall, the care of the dome is similar to that of a fiberglass boat, although since the dome is not in a marine environment, it will require less maintenance (and there is little chance for barnacles to grow!).

If you wish to keep it looking as new as possible for as long as possible, wash it with mild detergent (no abrasives) every 6-12 months to remove dirt and grime (add bleach if algae is a problem). You may want to apply rubbing compound and wax to the outer surface to help it remain "clean looking" longer, and help protect the finish. If the appearance is important to you, this should be done as soon as you build your dome if it is located close to trees, or if you have lots of dirt in the rain in your area. With occasional waxing the surface should last for many decades, though it may become slightly yellowish. You may wish to talk with auto or marine or boat supply stores for advice or materials for fiberglass maintenance and repair.

Three brands of fiberglass treatment that we have tried and like are

- 3M Marine Fiberglass Restorer and Wax (combines rubbing compound and wax in one application)
- IOSSO Fiberglass Reconditioner (restores color, removes oxidation and chalking, toll free number 1-888-747-4332)

- Meguiar's Cleaner and Wax (excellent cleaning and shine, easy to use)

It is possible that the surface of the fiberglass may become chipped or damaged during assembly. Or, after many years, it may develop some surface crazing or blisters.

Normally, these chips or discolorations will cause no functional problems. That is, while they may affect appearance, they do not significantly affect the strength of fiberglass beneath. However, if you do wish to repair the surface, you can use epoxy or polyester resin to cover the area for a functional fix, and add gel-coat for an aesthetic fix. Contact an auto or any marine or boat supply (see the Yellow Pages) for a fiberglass repair kit containing white Gel-coat (i.e., resin with white pigment) which can be applied easily.

If major damage to the dome occurs (e.g., you forgot and left the dome open during a major windstorm), virtually any damage can be functionally repaired using a fiberglass repair kit. You'll find a kit for this purpose in an auto parts shop or marine supply. If you wish, you may contact Technical Innovations for advice and/or replacement parts.

After 15-25 years, the surface may begin showing its age, usually by a dulling or chalking of the finish. (But then, so will we all!) Unless the surface is damaged, the only care really needed is wax. However, if dull or chalky you should be able to bring back the original finish by using an automotive polishing compound (not "rubbing" compound") and an electric buffer.

If you do have damage and wish to repair the surface, you may reapply gel coat, or you may paint the dome using a high grade epoxy paint. In either case, you will need to prepare the surface properly by cleaning and some abrasion. Again, give us a call, or check with your local marine or auto supply stores for advice and materials.

Bolt Hole Drilling Guide

PD10

Introduction and Terminology

When the dome has not been preassembled, there are a number of holes that need to be drilled in order to attach one fiberglass section to another or install miscellaneous add-on parts.

Throughout the process, it is extremely important to maintain roundness and levelness, while keeping a pleasing “cosmetic” appearance by aligning seams and keeping adjoining sections flush. Most times there will be a hole going through two pieces of fiberglass which will then be bolted tightly together. Even though the sections must be moved around until the final position meets the specifications, (especially base and wall rings), we know closely enough where the holes will be located to be able to drill one of the holes (“Guide”) then use that hole as a guide when we drill through the second piece (“Final”). The drill instruction identified as “Final” will in most cases be immediately followed by bolting the part or adjacent fiberglass section, together.

Wall and base ring sections join together end-to-end (“Overlap”), and bolt to the corresponding section directly below, except for the very bottom ring, (“Stack”).

The reference “Right” or “Left” has the orientation of standing outside the door (or “Home” position), facing the dome and looking in.

Construction Overview

The recommended dome construction steps are detailed in the manual, but an overview of this sequence is as follows:

1. Installation Preparation – Foundation, leveling, tools, organization and planning
2. Pre-drilling (guide holes)
3. Bottom ring (base or wall) prep and install
4. Mounting bottom ring (base or wall) to foundation
5. Installation of walls (if relevant)
6. Rotation system install (wheels and side rollers)
7. Install DSR
8. Construct dome halves
9. Install rear shutter panel
10. Install dome halves to DSR
11. Install shutter
12. Finish items

Bolt Hole Drilling Guide

1. Right Stub Section, Overlap, Guide *

The 90 degree wall sections each have one end “stepped in” (“male”) and the other end a “flat” continuation of the wall (“female”). On the two stub sections one has the “stepped in” end (on left side of door standing outside looking in) while the other has a flat end. Since all of the initial

“Guide” holes for base and wall ring sections are made at the “flat” end, only the right stub section is drilled at this time. Two holes are drilled (9/32 inch bit) on the “flat” end of each of the stub sections. The locations are, 2 inches down from the top and 2 inches up from the bottom, with both 1 & 1/8 inch in from the end edge.

2. Stub Sections, Stack, Guide*

The right and left stub sections will be “stacked” with the base ring stub at the top. The horizontal flanges (top and bottom) match up with the sections above and/or below. Where the bottom flange of one section is in contact with the top flange of the section below, three guide holes will be drilled (9/32 inch drill bits), for bolting the sections together. Two holes will be drilled on the “door” side (closed edge) and one on the side that overlaps the adjacent ring section. The two holes on the door side are staggered, with the inside one about ½ inch from the outside wall and ½ inch from the end cap, and the second ½ inch from the flange edge and 1 inch from the end cap. The third hole is centered on the flange, 12 inches from the overlap end. Drill these three holes in each of the sections EXCEPT the very bottom section (which will be attached to the foundation).

3. Stub Sections, Stack, Final*

The right and left stub sections are now “stacked” with the base ring stub at the top and the stub without guide holes at the bottom. The horizontal flanges (top and bottom) match up with the sections above and/or below. The sections should be all clamped together using a straight-edge along the sides to keep them in line. Where the bottom flange of one section is in contact with the top flange of the section below, the three holes will be used as guides to drill (9/32 inch drill bits), through the corresponding top flange for bolting the sections together.

4. Door Sections, Stack, Guide*

The door sections will be “stacked” with the base ring door (wheel hole) at the top. The horizontal flanges (top and bottom) match up with the sections above and/or below. Where the bottom flange of one section is in contact with the top flange of the section below, two holes will be drilled (9/32 inch drill bits), through the bottom flange for bolting the sections together. The two holes will be drilled, each approximately 4” in from door section sides and centered on the bottom flange. Drill these three holes in each of the sections EXCEPT the very bottom section (which will be closest to the foundation).

5. Door Sections, Stack, Final*

The door sections are “stacked” with the base ring door at the top. The horizontal flanges (top and bottom) match up with the sections above and/or below. The sections should be all clamped together using a straight-edge along the sides to keep them in line. Where the bottom flange of one section is in contact with the top flange of the section below, the two guide holes will be used to drill (9/32 inch drill bits), through the corresponding top flange for bolting the sections together.

6. Wheels, Final*

Locate the wheel cutouts in each base ring section (on the underside of the reverse flange). Find the center of each cutout and measure down the outside wall of the base ring $\frac{7}{8}$ inch (use the template provided with the dome hardware). Drill ($\frac{5}{16}$ inch bit) and then countersink the outside of the hole to a depth that results in the head of the $2\frac{1}{4}$ inch Flat Head bolt to be flush with the outside wall surface. There are two large cutouts for the optional ED motor assemblies. If you are not installing the ED10 system, drill similar wheel holes centered on these two cutouts.

7. Side Rollers, Final*

There are 16 side rollers that get distributed approximately equal distance apart around the top surface of the base ring (under the reverse flange). See **Figure 9B** in the manual for placement. The side roller is mounted horizontally on the top surface so that it extends between $\frac{1}{8}$ and $\frac{3}{16}$ inch out from the base ring wall surface. Measure $\frac{3}{4}$ inch inward (use template) and mark for the Side Roller mounting hole. Drill out these holes using a $\frac{13}{64}$ drill bit.

8. Hinge, Final (PD10 with Door)*

The hinge will first be mounted on the end caps of the right side door stack. The hinge is one inch shorter than the wall/base ring height to leave $\frac{1}{2}$ inch at each the top and bottom of the door. The hinge is positioned such that it is flush with the outside wall edge, pivot pin to the outside and held in place with two clamps. The hinge is attached using the two end holes then every other hinge hole in-between. Drill the holes, using the hinge holes as guides, with a $\frac{7}{32}$ inch drill bit. Bolt the hinge (6-32, $\frac{3}{4}$ inch flat head bolts) to the door. Position the door (and open side of hinge against the right wall stub cap end. Position so that door swings freely, then clamp into position. Drill wall side of hinge (using hinge holes as guides) with $\frac{7}{32}$ inch drill bit. The hinge is bolted using the top most and bottom most holes along with every-other set of holes between.

9. Base/Wall ring sections, Overlap, Guide*

The 90 degree wall sections each have one end "stepped in" ("female") and the other end a "flat" ("male"), continuation of the wall. All of the initial "Guide" holes for base and wall ring sections are made at the "flat" end, and all sections can be drilled at this time. Two holes are drilled ($\frac{9}{32}$ inch bit) on the "flat" (male) end of the section. Their locations are, 2 inches down from the top and 2 inches up from the bottom - with both $1\frac{1}{8}$ inch in from the end edge.

10. Bottom base/wall ring, Overlap, Final

The 90 degree wall sections each have one end "stepped in" ("female"), that slide in behind the "flat" end of the adjoining sections and/or stub sections. The bottom ring is fitted together in this fashion until a continuous circle is formed on top of the pad or mounting surface. Using

clamps, this ring is adjusted until it is circular and meets the circumference measurement tolerances. All of the initial "Guide" holes for these ring sections are on the outside of each joint and are used as guides to drill the Final overlap holes (9/32 inch bit). The sections are bolted at this point to form the solid bottom ring.

11. Bottom base/wall ring, Mounting Flange, Final

With the bottom ring of correct circumference, circular, and placed on the mounting surface at the desired location, the anchor holes can be drilled. Anchor holes will be made through the bottom flange of this ring approximately every 15-18 inches around the circumference. Using a small (1/8 inch) bit, drill "Guide" holes through the flange and into the mounting surface below. Depending upon material the ring may need to be moved and holes for bolt anchors drilled out. The ring is moved back into place and the mounting holes in the fiberglass flange drilled out to match the anchor bolt size decided upon (normally 3/8 inch bolt).

12. Wall ring sections, Stack, Guide*

Four holes (9/32 inch bit) are drilled into the bottom horizontal flange of all 90 degree base ring and wall ring sections, **EXCEPT** the ones making up bottom most ring – which may now already be mounted to the pad or structure. One hole is drilled in the center of the flange, 8 inches from the flat ("male") end. The second hole is centered on the flange 11 inches from the "stepped in" (female) end. The remaining two holes are evenly spaced between the end two, with 24 inches between each of the holes.

13. Wall ring sections, Overlap, Final

With the ring below of correct circumference, circular, and bolted to either another ring below it, (or the mounting surface), the next ring up is fit together, at positioned on top of that ring. Using clamps the ring is centered on the ring below and adjusted such that it is circular and of the correct circumference. With each ring segment securely clamped together (and to the ring below), final holes are drill through the "stepped-in" female ends from the outside, using the corresponding male end guide holes.

14. Wall ring sections, Stack, Final

With the ring of correct circumference, circular, bolted at the overlap ends and securely clamped to the ring below it, the final stack holes are drilled from above, using the stack guide holes previously drilled in its bottom flange.

15. Upper Door Latch, Final

The upper latch is made up of two parts, the “latch” section (which is mounted on the inside upper left hand corner of top door section), and the “receiver” section (which is mounted on the inside upper right hand corner of the top - base ring - left stub section). (Remember that even though these are mounted on the inside of the door, the left/right orientation references are ALWAYS from the outside of the dome looking in). Position the “latch” bracket against the door section corner so that it is flush with the outside of the section flanges. Drill two (use 9/32 inch drill bit) evenly spaced and centered holes through the top and side flanges and bracket. The hole on the side flange will be countersunk for flathead bolts. Repeat the same steps for the “receiver” bracket in the stub base ring section,

16. DSR overlaps, Final

With the wall/base rings of correct circumference, circular, and bolted together, the DSR sections are set into place with each end overlapping the adjacent. Once adjustments are made to obtain the correct DSR circumference, a 6/32 hole is drilled in the center of each overlap section.

17. Top Shutter, J-Guides, Final*

Five J-Guides (2 holes each - 3/16 inch bit) are mounted onto each of the side flanges of the top shutter panel. One of the J-Guides should be used as a template for the pair of holes, and positioned such that loop section only extends past the flange edge. The first pair holes are drilled 4 inches in from one end of the shutter panel and the second pair 4 inches in from the other end. The remaining 3 are evenly spaced between the first two (approximately 15 ½ inches between each). All 20 holes (both sides) will be counter-sunk on the inside of the flanges to prepare for the 10-32 flathead bolts.

18. Top Shutter, Latch Bars, Final*

The shutter latch bars (long – 5 holes and short – 4 holes) are mounted on the inside and near the ends of the top shutter. The long is near the front edge and the short near the rear edge. In both cases a centerline is 7.75 inches in from each shutter edge. The latch bars are each centered on the shutter with the latch holes centered on that line. The hole locations are marked on the outside (white) surface. Look carefully and you will see the small cross marks. Drill 9/32 inch holes at each point (total of 9 holes). Place the latch bar over the holes to make sure that the last two markings are still lined up with the first 2/3 holes drilled. It is very important that the latch bars are parallel to the shutter edge.

Note: There should be marks on the outside (white) surface of the shutter that locate these holes. Use these marks as your drill guide. Also, due to the tight tolerance of the ¾” bolts you should first tighten the bolts onto the shutter (pulling the carriage bolt head flush), then push the latch bar onto the bolts and tighten.

19. Front Shutter, Handles, Final*

A centerline should be drawn 5 inches in from front edge of the front shutter. The shutter handles (one will be mounted on the outside while the other is on the inside – each sharing the two holes/bolts) are each centered on the shutter with the handle holes centered on that line. One of the handles can be used as a guide. Mark the bolt hole locations and drill 9/32 inch holes at each end (total of 2 holes).

20. Rear Shutter, Shutter Catchers, Final*

The pair of shutter catchers (which are mounted on the outside at the bottom of the rear shutter panel) have a right and a left unit. They are positioned such that they are flush with the side and up $\frac{3}{4}$ " from the bottom edge at the outside bottom corner of rear shutter panel, and the "arm" with wind restraint cable hole, extends out from panel. Mark and drill four 9/32 holes (two for each shutter catcher).

21. Rear Shutter, Side Flanges, Guide*

Seven holes (9/32 inch bit) are drilled into both sides (the side flanges) of the rear shutter panel. The first hole is drilled 4 inches up from the bottom tab, followed by the next 6, each $12\frac{1}{2}$ inches apart. The 7th and last bolt is $2\frac{1}{2}$ inches up from the 6th, which will leave it about $2\frac{1}{2}$ inches from the top flange edge. Each hole will then be countersunk (on the outside of the shutter side flanges) since flathead bolts will be used to attach the rear shutter panel to the rear dome quadrants. All holes are approximately centered on the flange width.

22. Front Right Dome Quadrant, DSR Flange, Guide

Five holes (9/32 inch bit) are drilled into the bottom horizontal, DSR, flange of the front right dome quadrant. The first hole is drilled 5 inches from the front edge followed by the next 4, each 16" apart. All holes are approximately centered on the flange width.

23. Front Left Dome Quadrant, DSR Flange, Guide

Five holes (9/32 inch bit) are drilled into the bottom horizontal, DSR, flange of the front left dome quadrant. The first hole is drilled 5 inches from the front edge followed by the next 4, each 16" apart. All holes are approximately centered on the flange width.

24. Front Right Dome Quadrant, Greenwich Flange, Guide

Seven holes (9/32 inch bit) are drilled into the center, Greenwich flange of the front right dome quadrant. The first hole is drilled 3 inches up from the bottom edge (next to DSR flange),

followed by the next 5, each 11 ½" apart. All holes are approximately centered on the flange width.

25. Rear Left Dome Quadrant, Greenwich Flange, Guide

Seven holes (9/32 inch bit) are drilled into the center, Greenwich flange of the front right dome quadrant. The first hole is drilled 3 inches up from the bottom edge (next to DSR flange), followed by the next 5, each 11 ½" apart. All holes are approximately centered on the flange width.

26. Rear Right Dome Quadrant, DSR Flange, Guide

Five holes (9/32 inch bit) are drilled into the bottom horizontal, DSR, flange of the rear right dome quadrant. The first hole is drilled 5 inches from the rear edge (tab) followed by the next 4, each 16 inches apart. All holes are approximately centered on the flange width.

27. Rear left Dome Quadrant, DSR Flange, Guide

Five holes (9/32 inch bit) are drilled into the bottom horizontal, DSR, flange of the rear left dome quadrant. The first hole is drilled 5 inches from the rear edge (tab) followed by the next 4, each 16 inches apart. All holes are approximately centered on the flange width.

28. Rear Right Dome Quadrant, Greenwich Flange, Final

The Rear Right and Front Right dome quadrants are joined together at the Greenwich Flange to form the Right Dome Half. Bring and clamp the two quadrants together, making sure that the seams line up on the outside and that the bottoms are flat/horizontal. Using the guide holes drilled in the Front Right Dome Quadrant, drill 9/32 inch holes through the Rear quadrant Greenwich Flange.

29. Front Left Dome Quadrant, Greenwich Flange, Final

The Rear Left and Front Left dome quadrants are joined together at the Greenwich Flange to form the Left Dome Half. Bring and clamp the two quadrants together, making sure that the seams line up on the outside and that the bottoms are flat/horizontal. Using the guide holes drilled in the Front Left Dome Quadrant, drill 9/32 inch holes through the Rear quadrant Greenwich Flange.

30. Rear Right Dome Quadrant, Shutter Flange, Final

Once the rear shutter panel is positioned (overlapping the shutter flanges of the two rear dome quadrants – with bottom edge of shutter 1 inch below the bottom tabs of the quadrant shutter

flange), the guide holes drilled previously in the shutter flanges will be use to drill the final seven (9/36 inch drill bit) holes used to attach the right rear quadrant to the rear shutter panel.

31. Rear Left Dome Quadrant, Shutter Flange, Final

Once the rear shutter panel is positioned (overlapping the shutter flanges of the two rear dome quadrants – with bottom edge of shutter 1 inch below the bottom tabs of the quadrant shutter flange), the guide holes drilled previously in the shutter flanges will be use to drill the final seven (9/36 inch drill bit) holes used to attach the left rear quadrant to the rear shutter panel.

32. Right Dome Half, Wind Restraint, Final

Start at seam of dome quadrants (top, middle); measure **BACK** 7 inches; go out from shutter flange 3 inches; drill ¼" hole for cable post

Measure **FORWARD** 21 inches; go out from shutter flange 3 inches; drill ¼" hole for mounting cable post.

Measure **FORWARD** 21 inches; go out from shutter flange 1.5 inches; drill ¼" hole for mounting Spring Post Assembly.

Start at the rear of dome half; measure forward (up) 25 inches from bottom of shutter flange tab; go out from shutter flange 3 inches; drill ¼" hole for mounting cable post.

Measure **FORWARD** 18 inches; go out from shutter flange 3 inches; drill ¼" hole for mounting cable post.

33. Left Dome Half, Wind Restraint, Final

Start at seam of dome quadrants (top, middle); measure **BACK** 7 inches; go out from shutter flange 3 inches; drill ¼" hole for cable post

Measure **FORWARD** 21 inches; go out from shutter flange 3 inches; drill ¼" hole for mounting cable post.

Measure **FORWARD** 21 inches; go out from shutter flange 1.5 inches; drill ¼" hole for mounting Spring Post Assembly.

Start at the rear of dome half; measure forward (up) 25 inches from bottom of shutter flange tab; go out from shutter flange 3 inches; drill ¼" hole for mounting cable post.

Measure **FORWARD** 18 inches; go out from shutter flange 3 inches; drill ¼" hole for mounting cable post.

34. DSR, Final

Once dome halves are properly positioned, the rear shutter panel is bolted in place and the front shutter opening spacers are in place the final DSR holes can be drilled. Using the guide holes previously drilled in the DSR flanges of the four dome quadrants, final holes will be drilled

(9/32 inch drill bit) down through the DSR flange. Each hole will then be countersunk from the bottom (underside of DSR) as flathead bolts will be used to attach the dome to the DSR.

35. DSR Swing-out Safety Brackets, Final

The two DSR Swing-out Safety Brackets are mounted on the top door section and are used to prevent the swing-out from wildly moving in the open direction by itself and possibly damaging the swing-out hinge. Using the brackets as guides, position each 2 inches from the left and right edges of the top door section, and at a height such that they project above the bottom of the DSR flange by about ½ inch. Drill the 9/32 inch holes (total of 4).

36. Lower Door Latch, Final

The Lower Door Latch is a spring driven “drop-down deadbolt” to lock the lower end of the door to the foundation. The slide bolt assembly will be mounted on inside left side flange of the bottom door section. (Remember that even though these are mounted on the inside of the door, the left/right orientation references are ALWAYS from the outside of the dome looking in). Center the flange on the side flange and adjust the height to a position that when the slide bolt barrel is fully extended, it will go into the foundation approximately 1/8 inch. Drill the four holes and countersink on the outside for flathead bolts.

37. Soffit, Final

The soffit is mounted between the rear shutter panel and the reverse flange portion of the base ring to cover the gap created at that point. Position the soffit under the reverse flange and onto the DSR. Check to make sure that it will not interfere with rotation. Drill a hole (9/32 inch drill bit) near each end through the soffit to line up with the shutter catcher bolts. Three holes are drilled on the base (about 3” from each edge and in the center) to bolt to the DSR. These will be countersunk on the bottom of the DSR for the flat head bolts.

38. DSR Linch Pin, Final

The DSR linch pin prevents the dome from rotating in storms and very high winds. This is inserted through the equatorial flange, DSR and flat underside of the reverse flange. Measure approximately 12 inches on either side of the door and drill 3/8 inch holes down through the dome half equatorial (or DSR) flange, the DSR and the lower surface of the reverse flange at the top of the base ring.

***This step can be done indoors (if weather is not so nice) and in some cases is easier to complete on a work bench or table.**

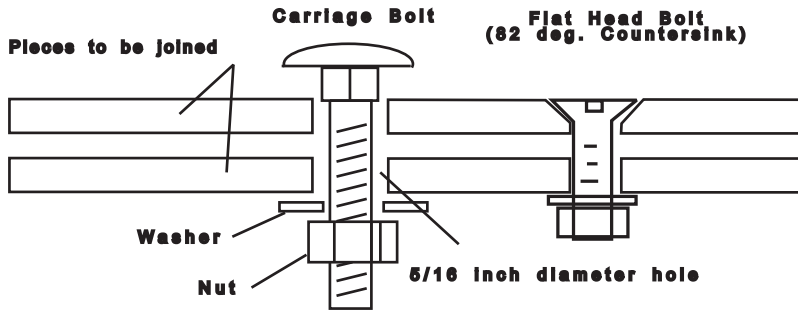

**Figure 1
Bolt Detail**

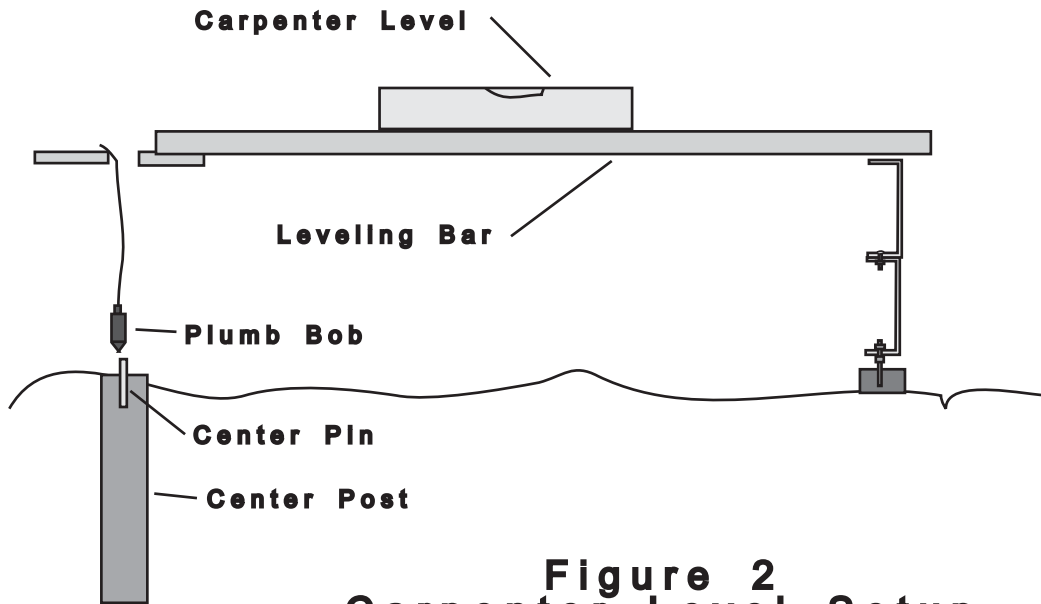

**Figure 2
Carpenter Level Setup**

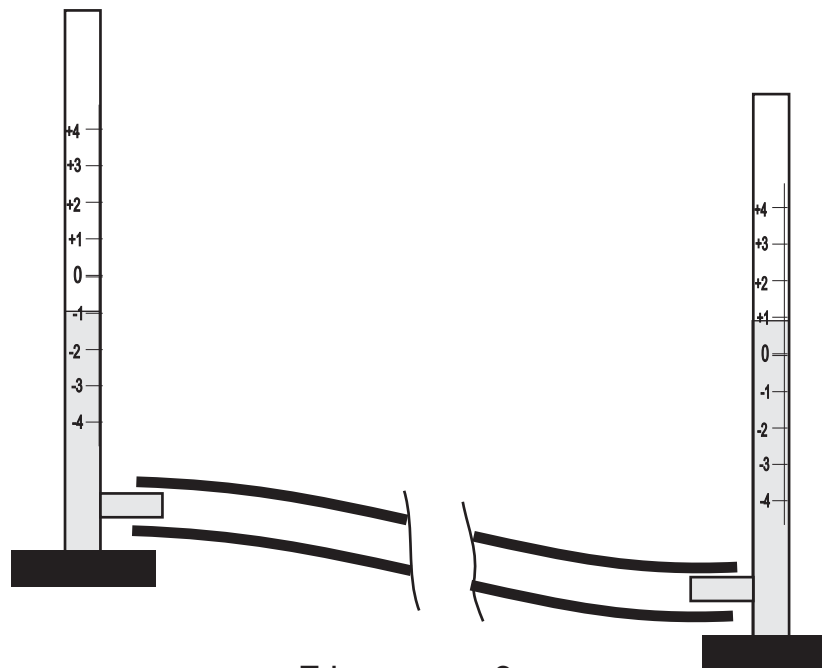

**Figure 3
Water Level**

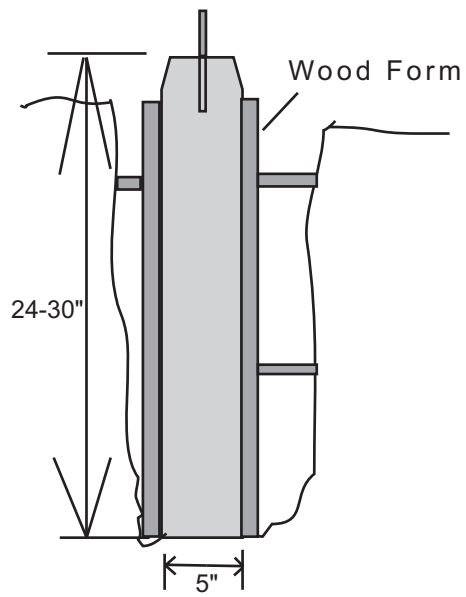

Figure 4
Ring Foundation Cross-section
(Poured Concrete)

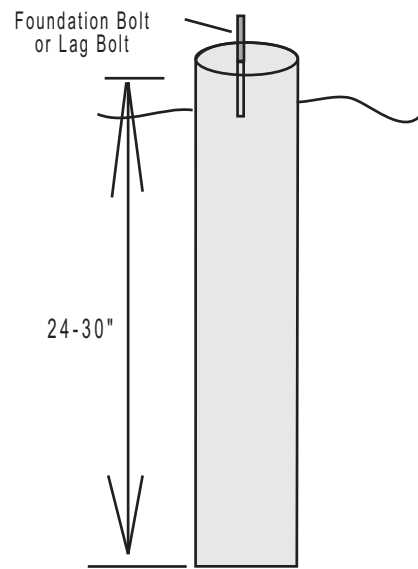

Figure 6
Wood Pier Foundation
(Post in Ground)

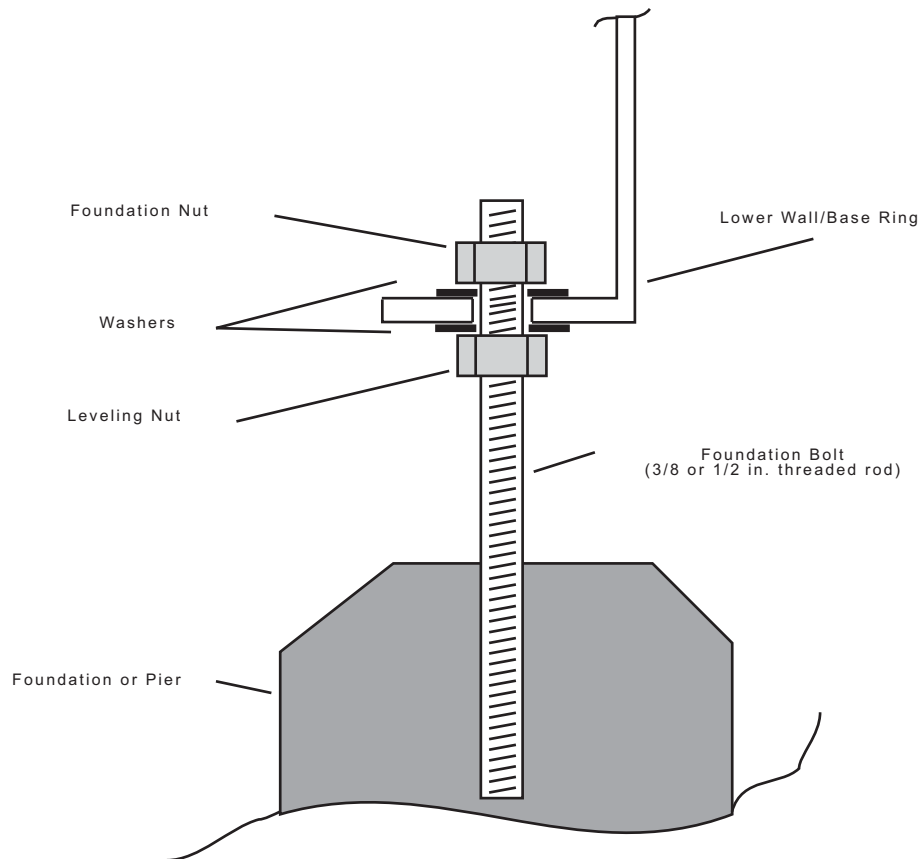
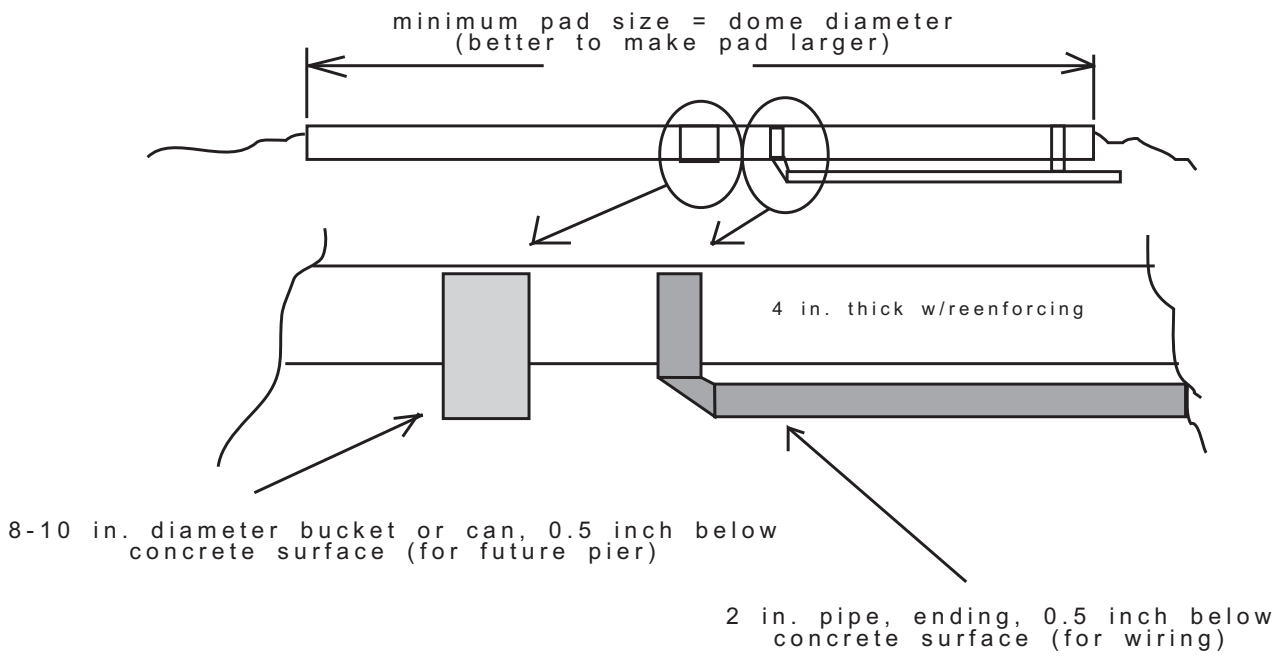
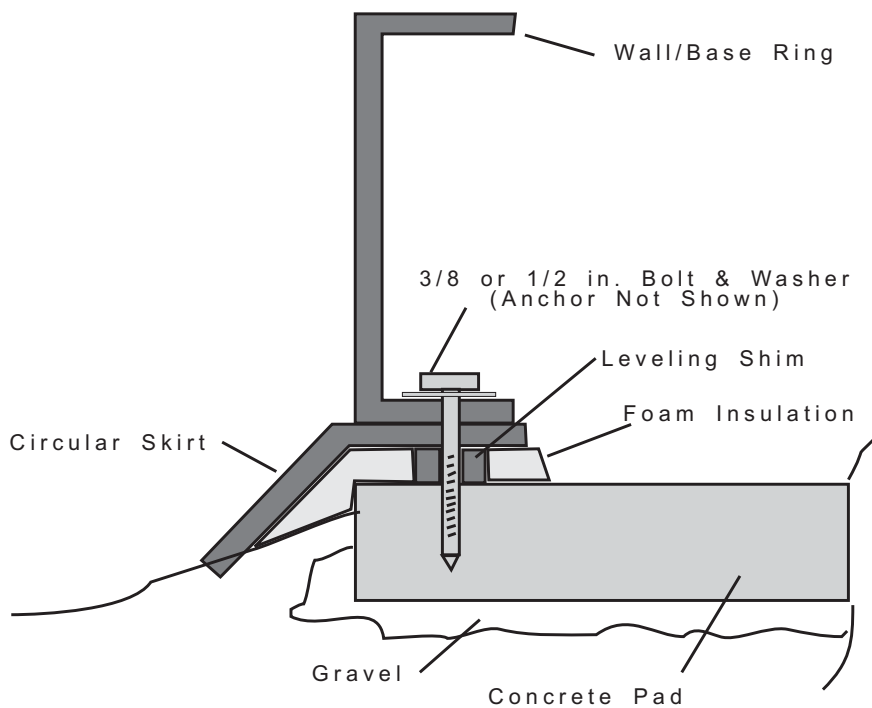

Figure 5
Foundation Bolts & Leveling



CONCRETE PAD DETAIL



FOUNDATION MOUNTING AND SKIRT DETAIL

Pad with Bolts & Shims Figure 7

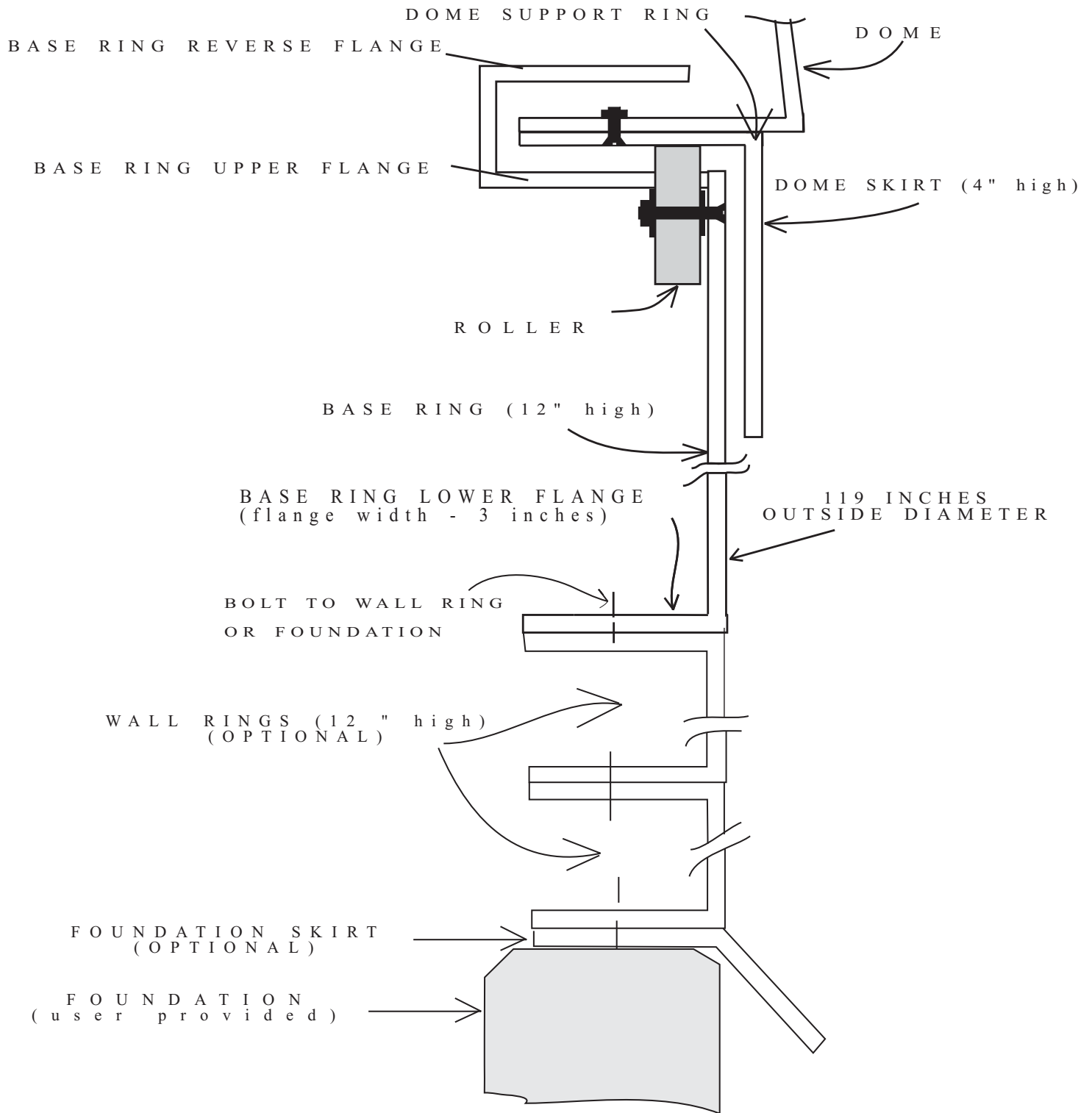

PD-10
Wall/Base Ring Structure Figure 9

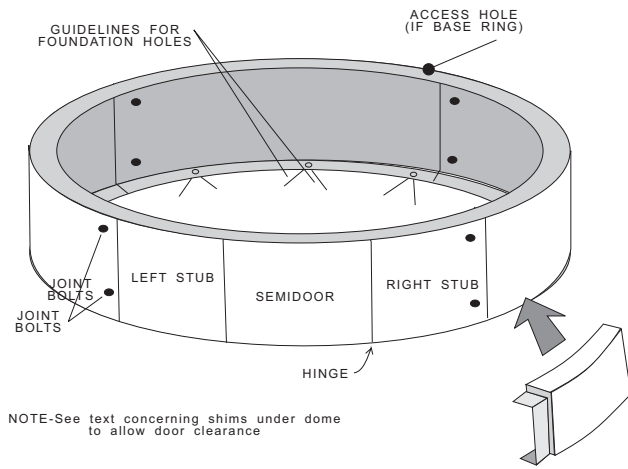

FIRST RING INSTALLATION

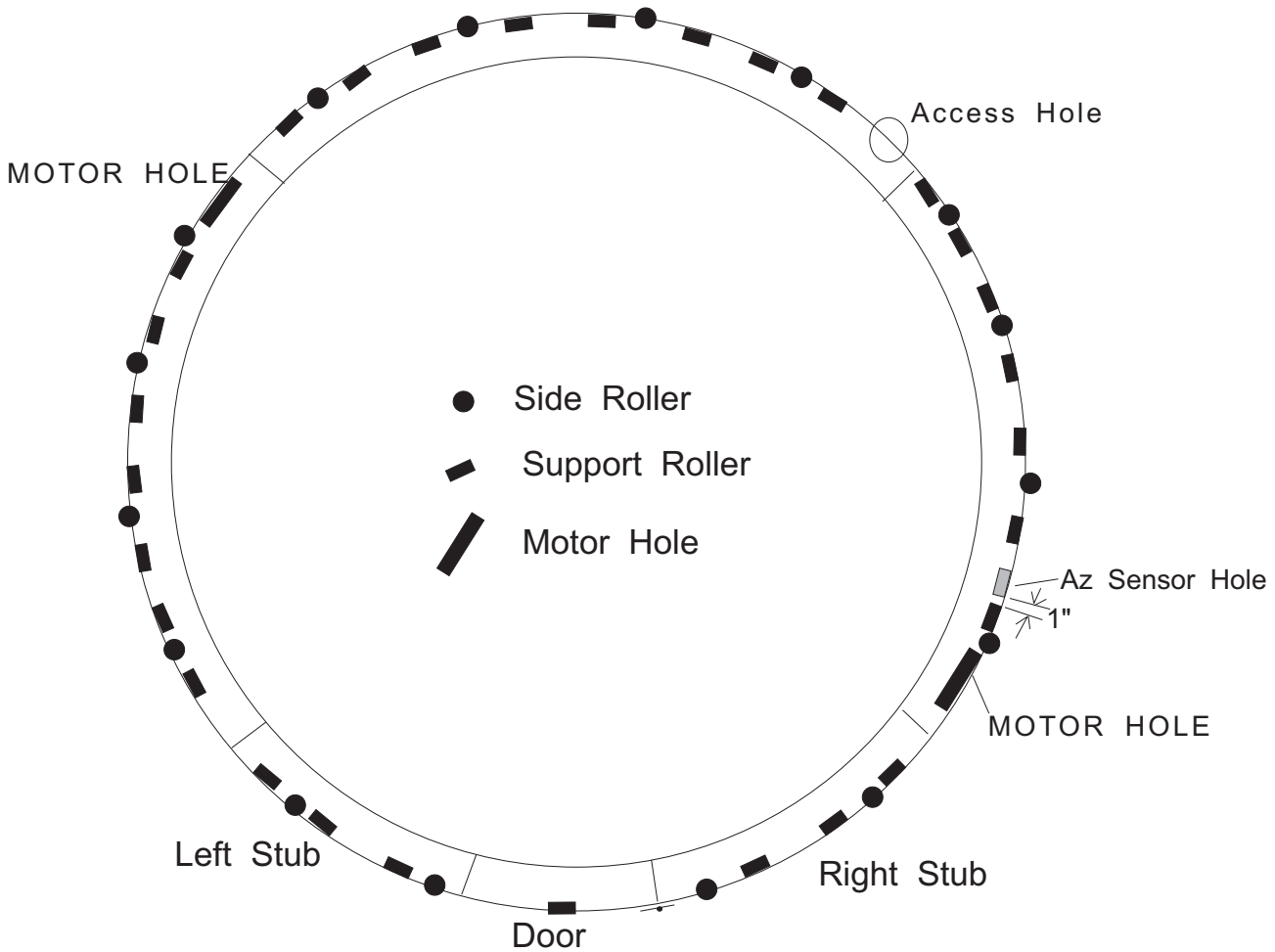

FRONT

BASE RING ARRANGEMENT

PD10

FIGURE 9B

Technical Innovations, Inc.
 22500 Old Hundred Road
 Barnesville, MD 20838

PD116A
 030201

FRONT SHUTTTER - PARTIALLY RETRACTED

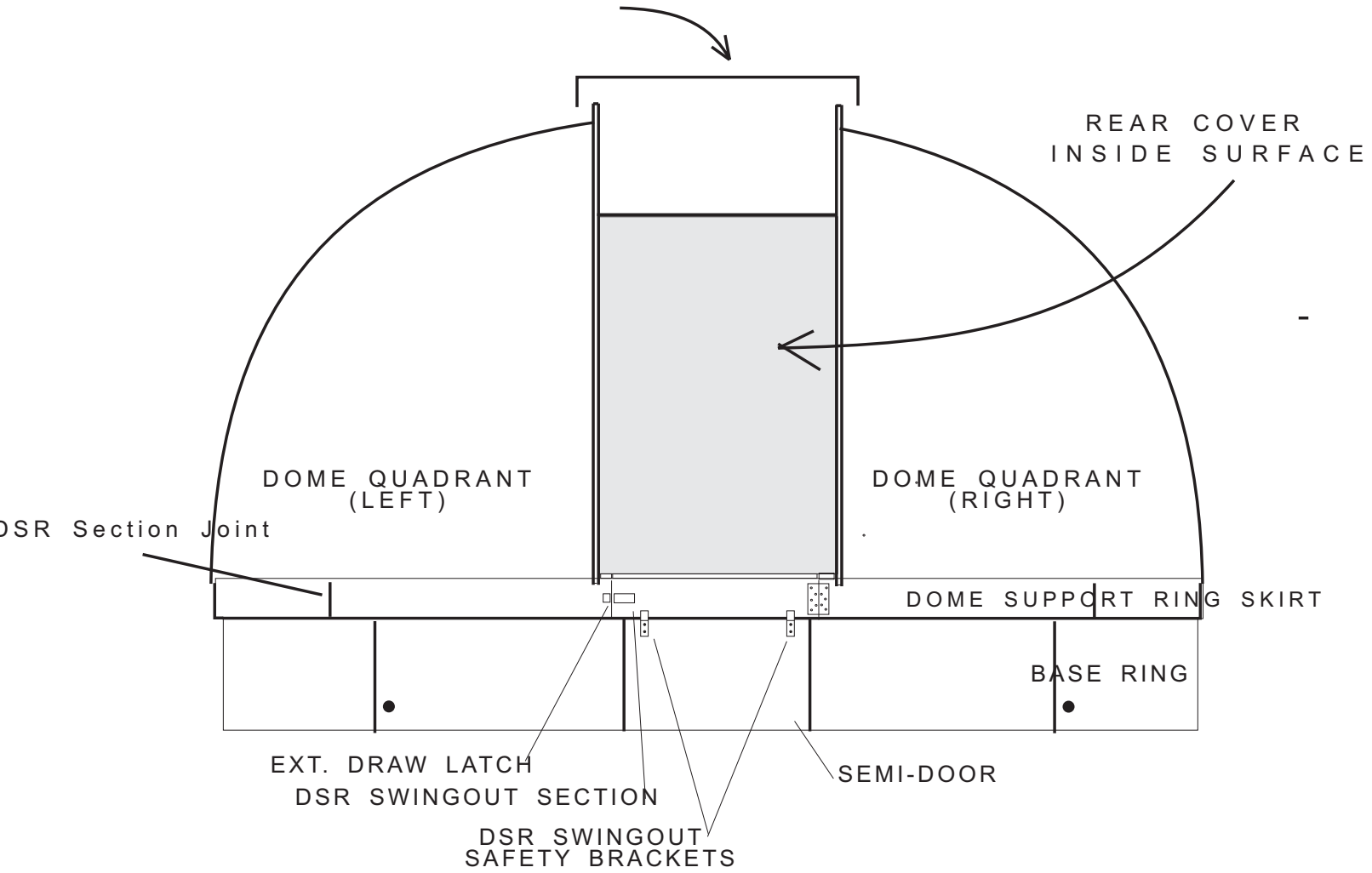

Front View PRO-DOME Figure 10

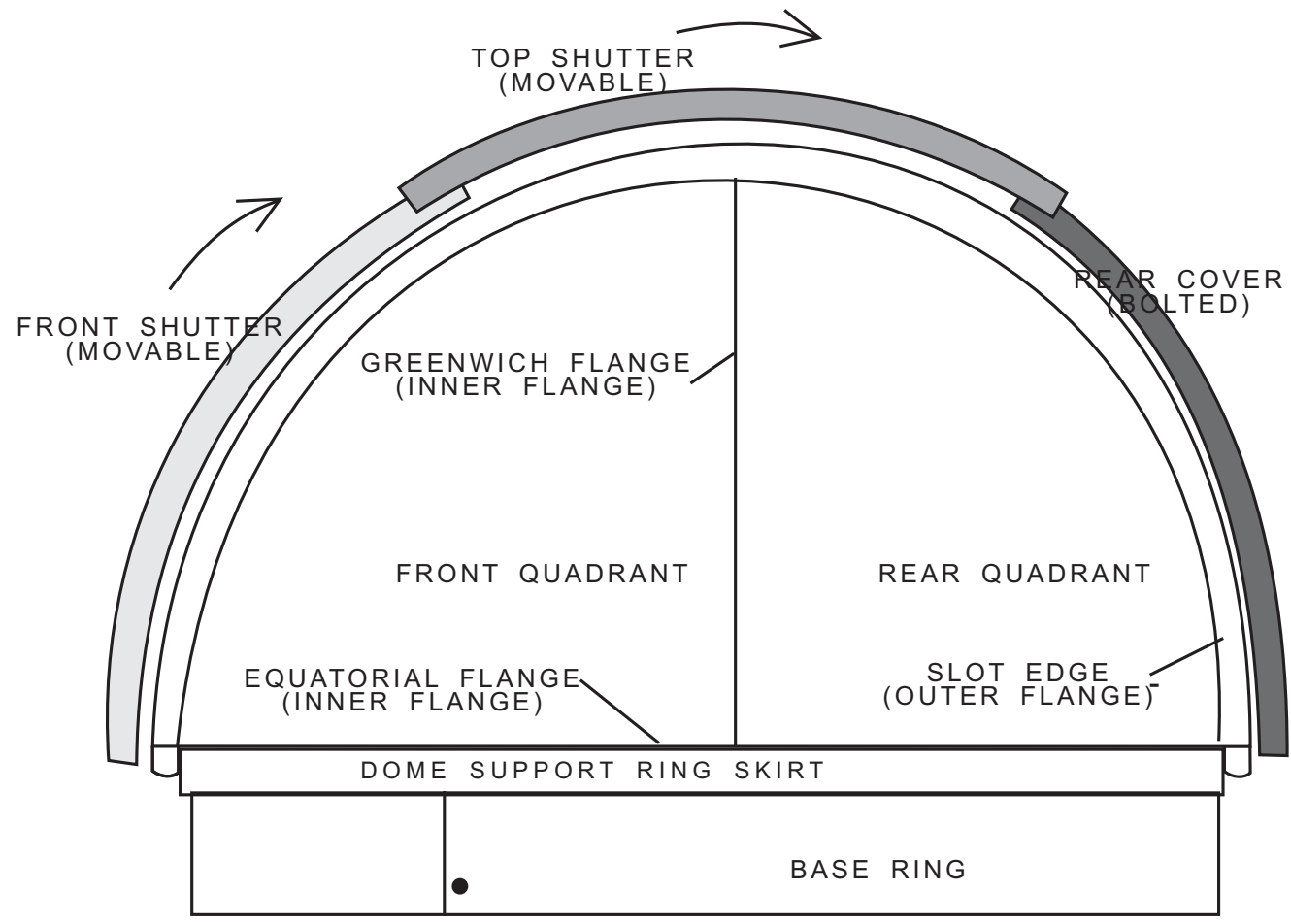

- NOTES:
1. SHUTTERS & REAR COVER SHOWN REMOVED
 2. 6'DOME HAS TWO HALVES INSTEAD OF FOUR QUADRANTS

FIGURE 10B
 SIDE VIEW, PRO-DOME - HOME-DOME

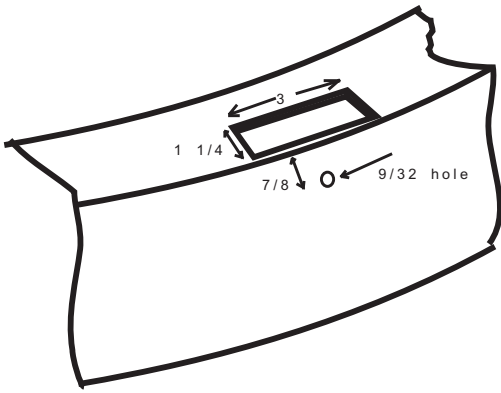

BASE RING - ROLLER HOLE

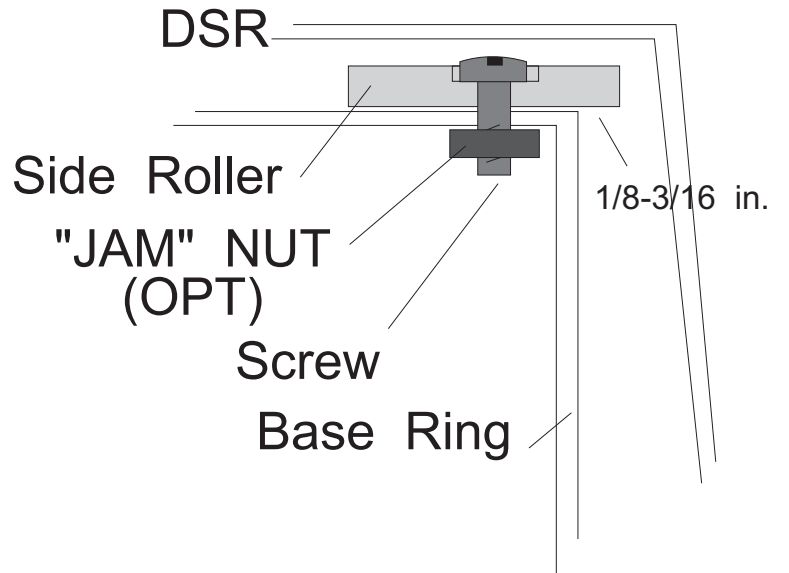
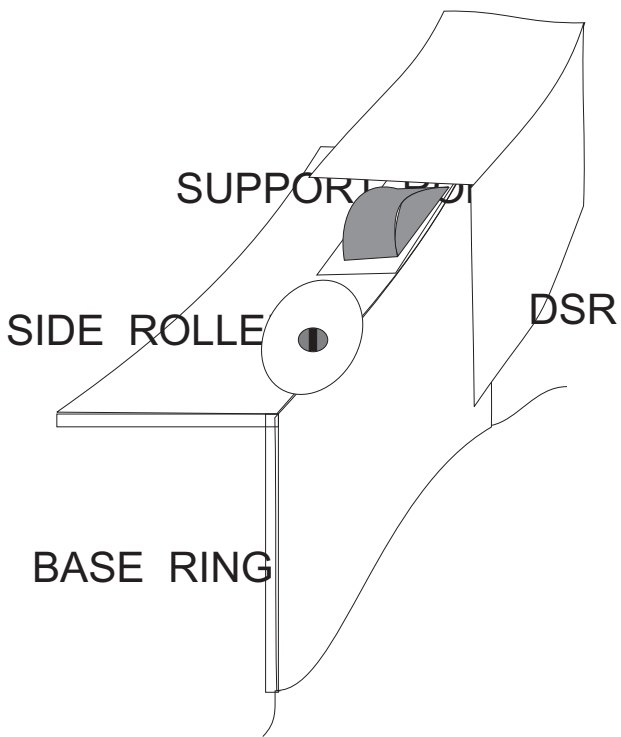
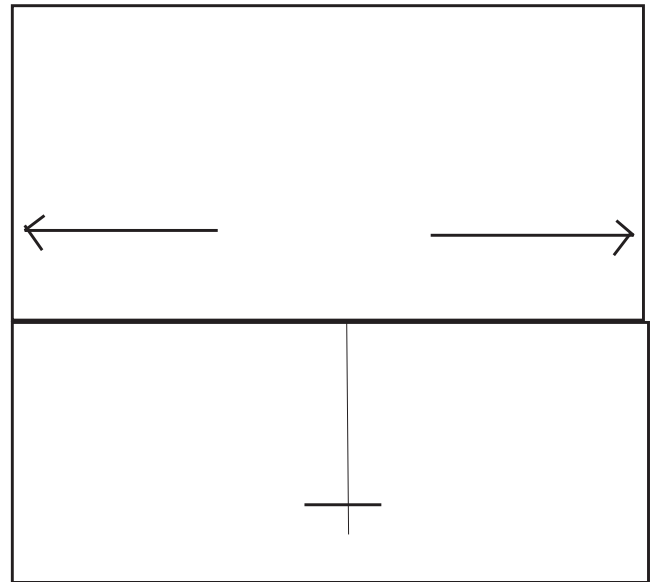

ROLLERS FIG 11

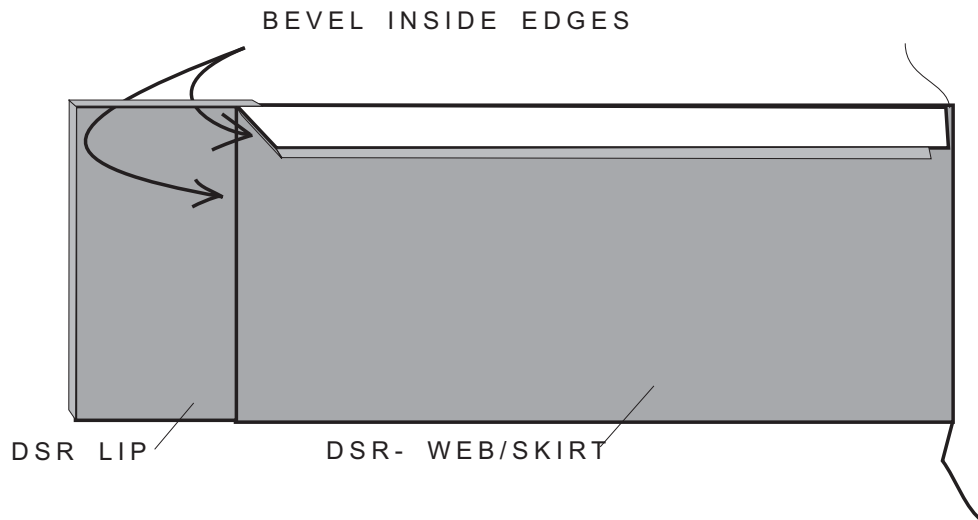

DSR - BEVELS
Figure 12

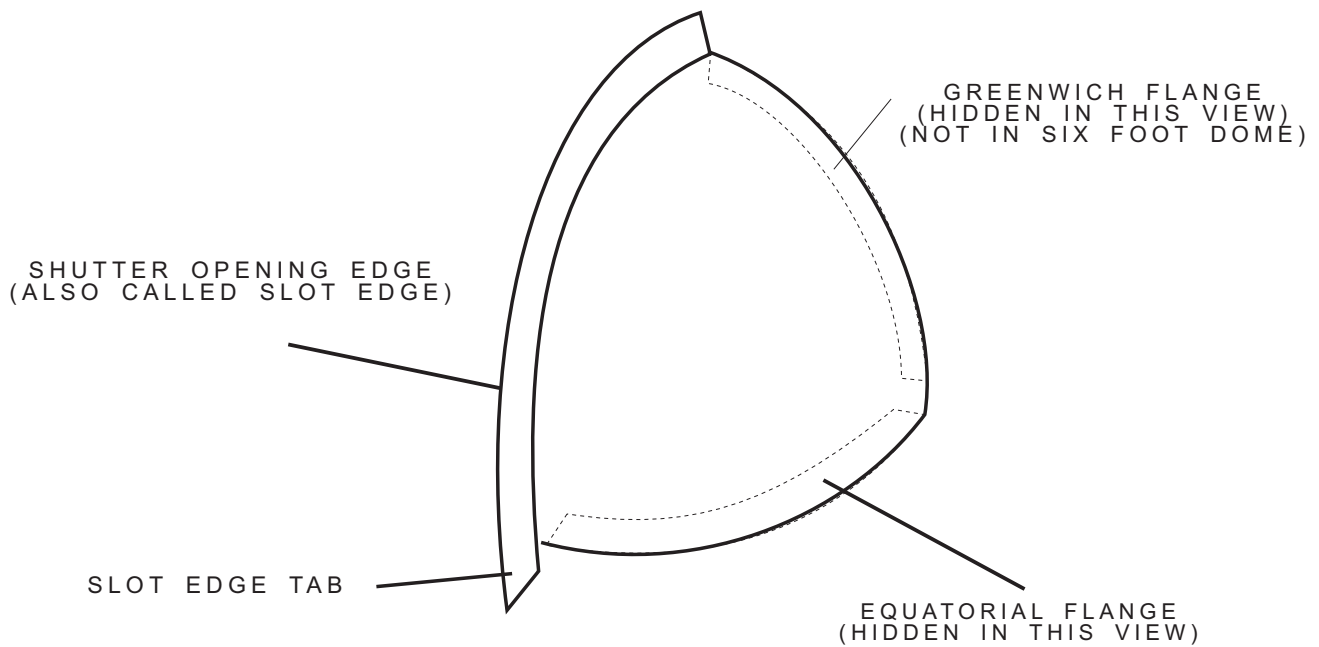

RIGHT FRONT DOME QUADRANT
FLANGE NOMENCLATURE
Figure 13

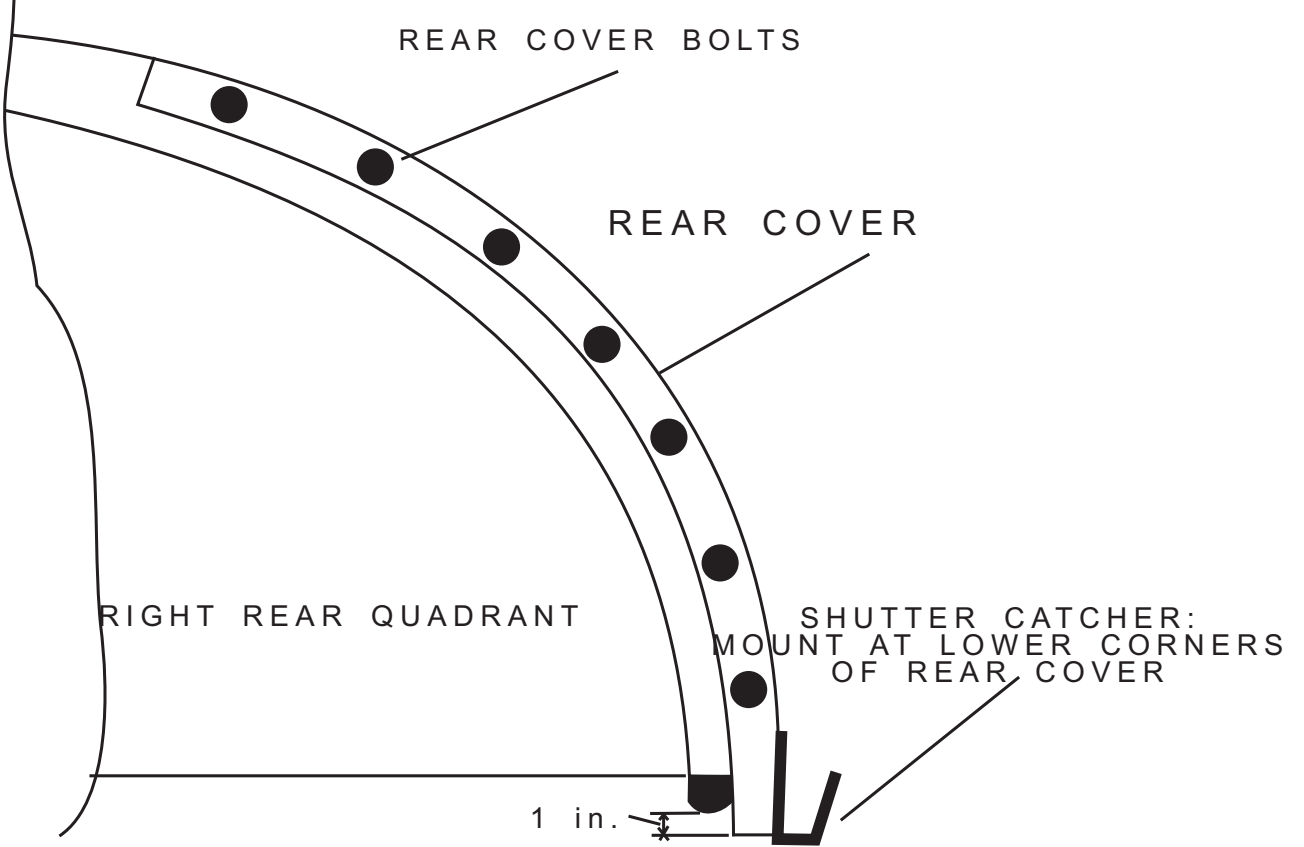

REAR COVER INSTALLATION
Figure 14

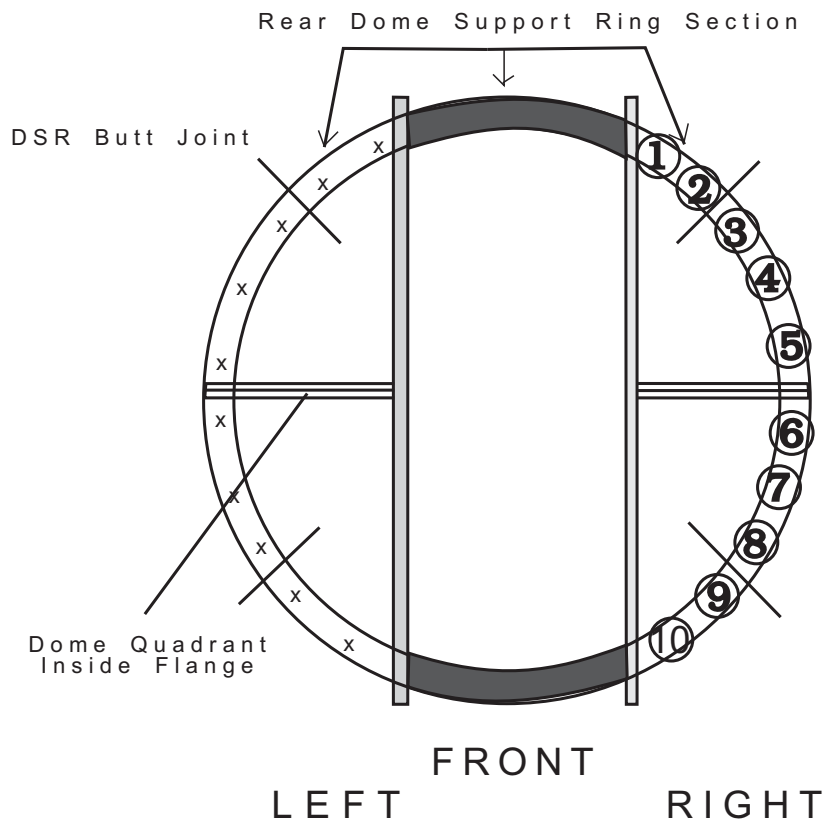

Quadrant: Bolt Identification
Figure 15

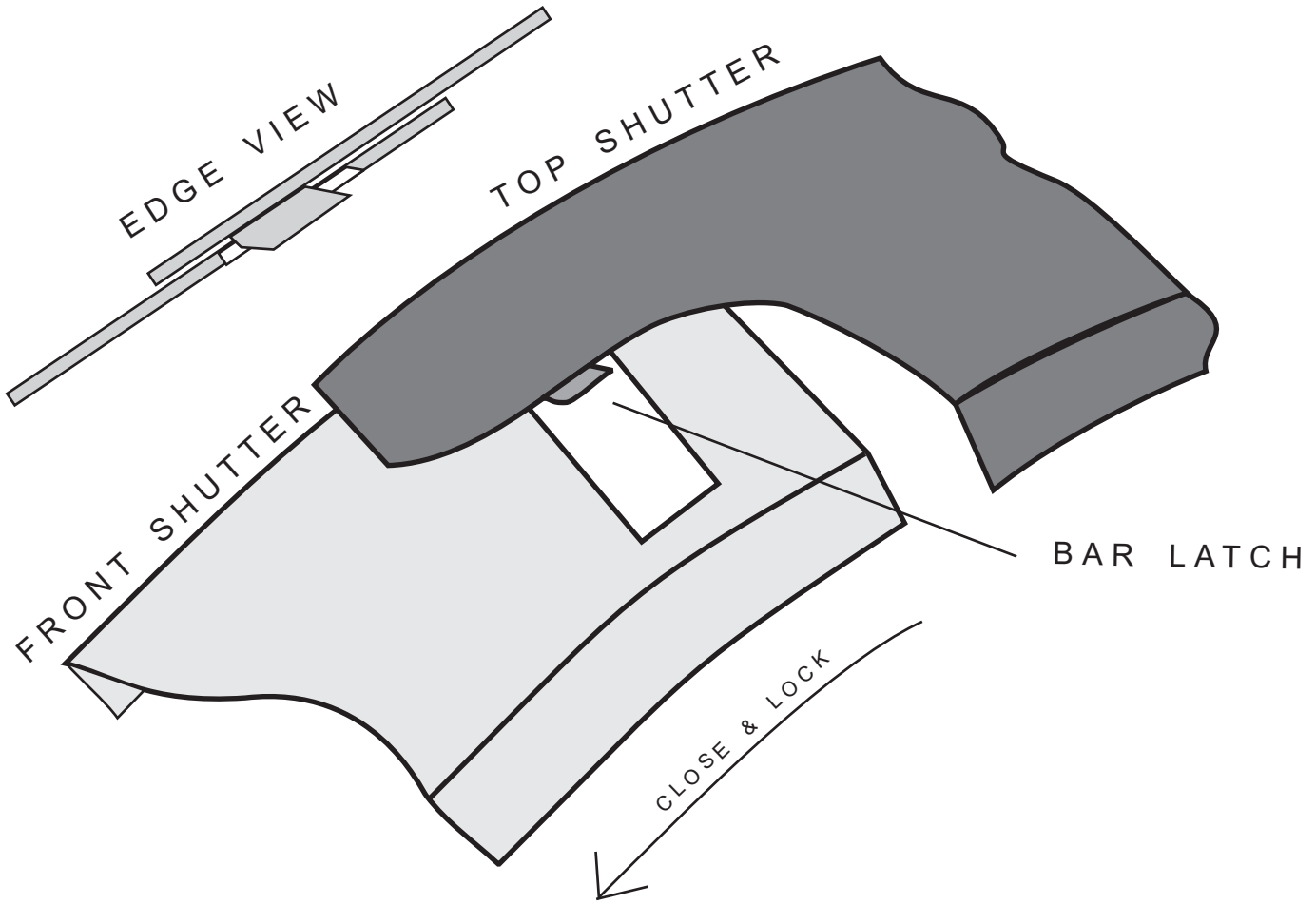

FRONT SHUTTER LATCH CUT-AWAY

(REAR COVER LATCH SIMILAR)

FIG 16

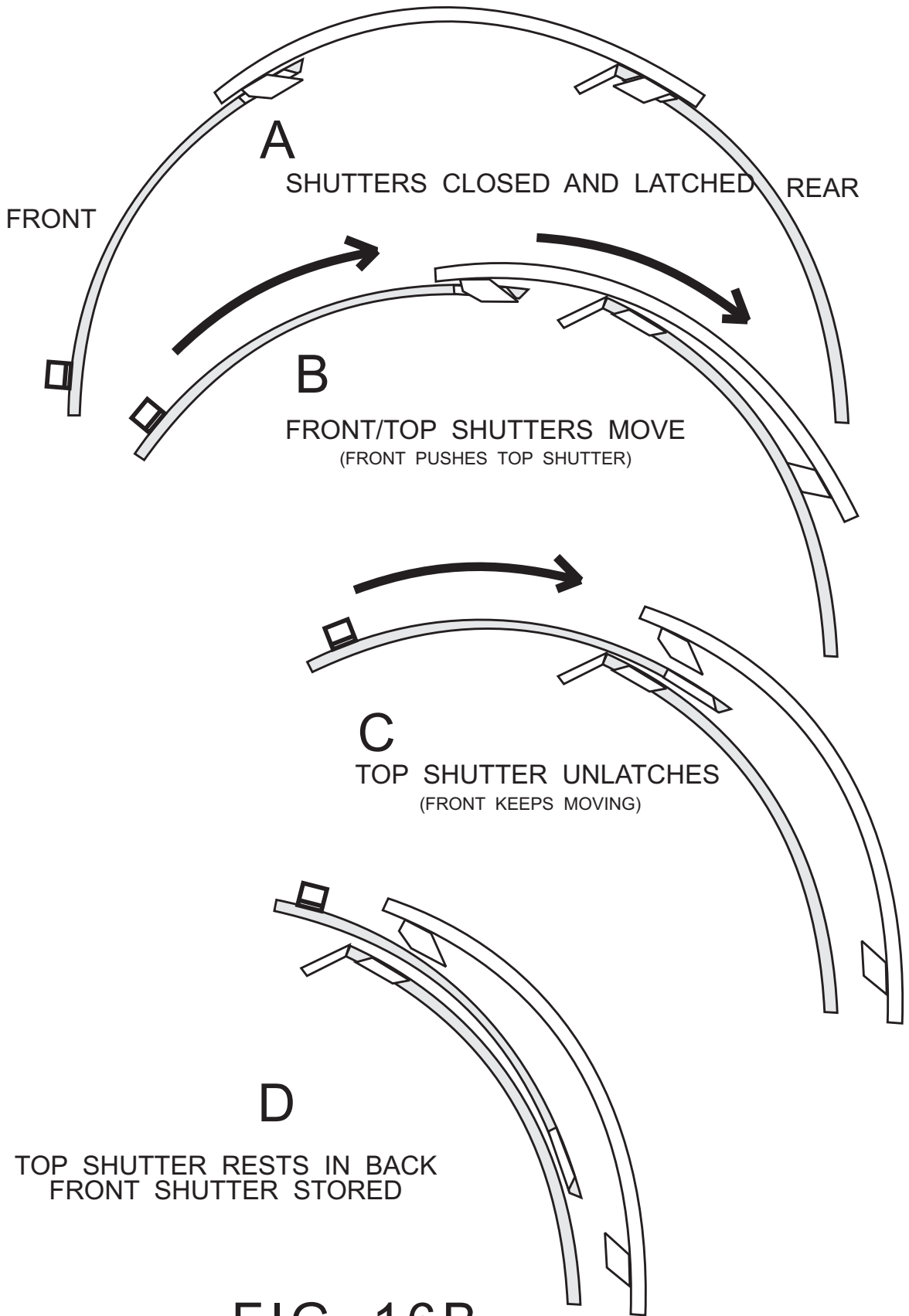
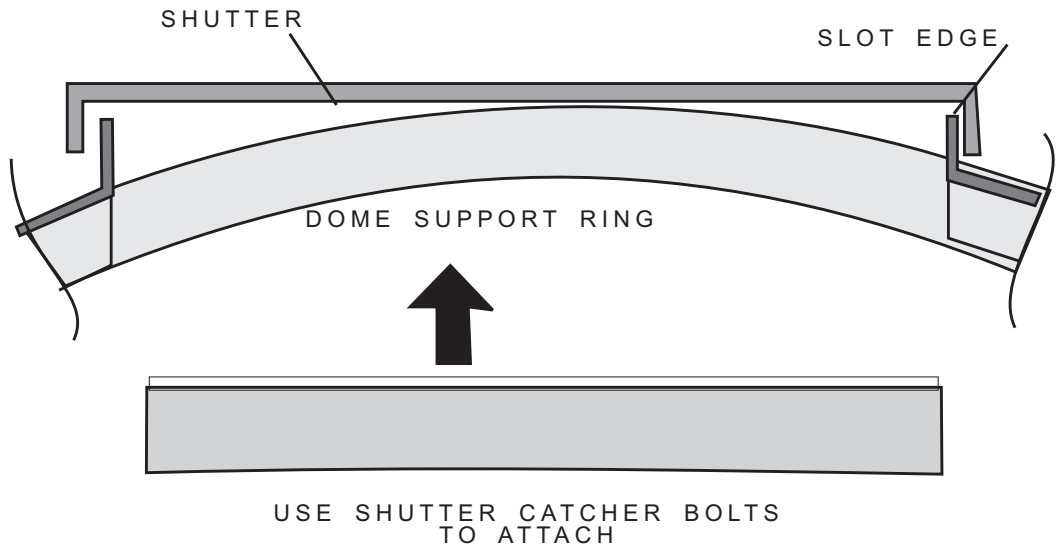
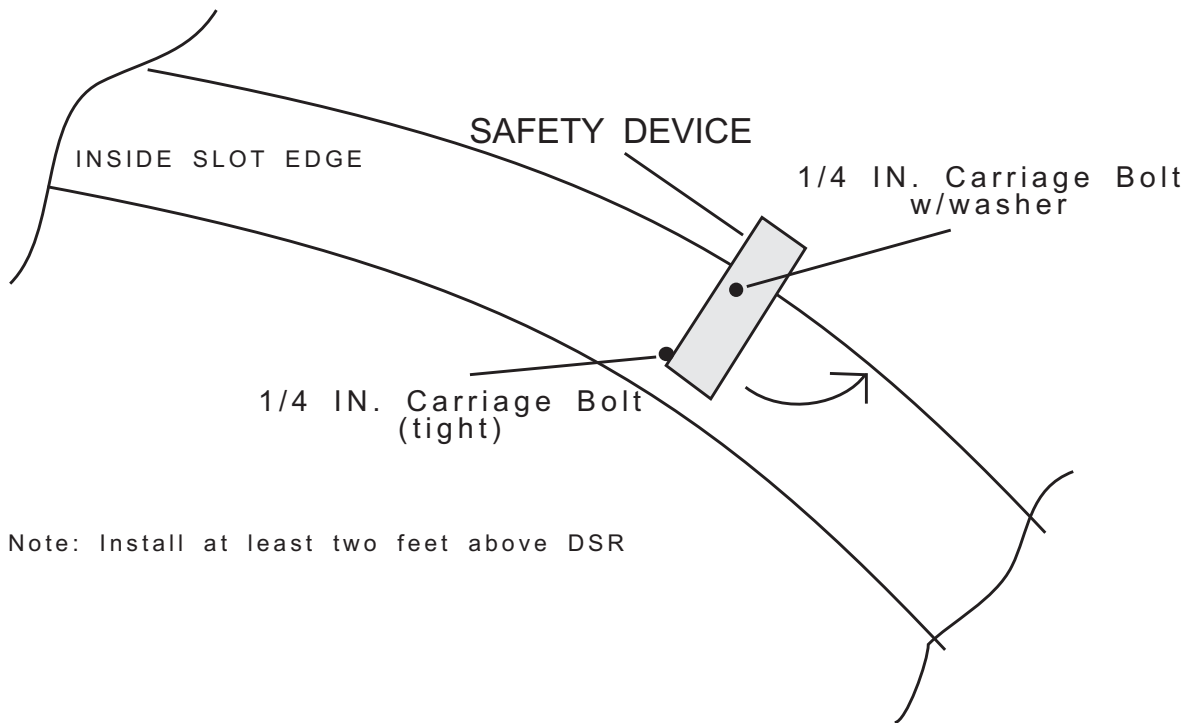

FIG 16B
SHUTTER OPERATION

NOT TO SCALE



SOFFIT (PRO-DOME ONLY)
Figure 17



SHUTTER SAFETY DEVICE
Figure 18

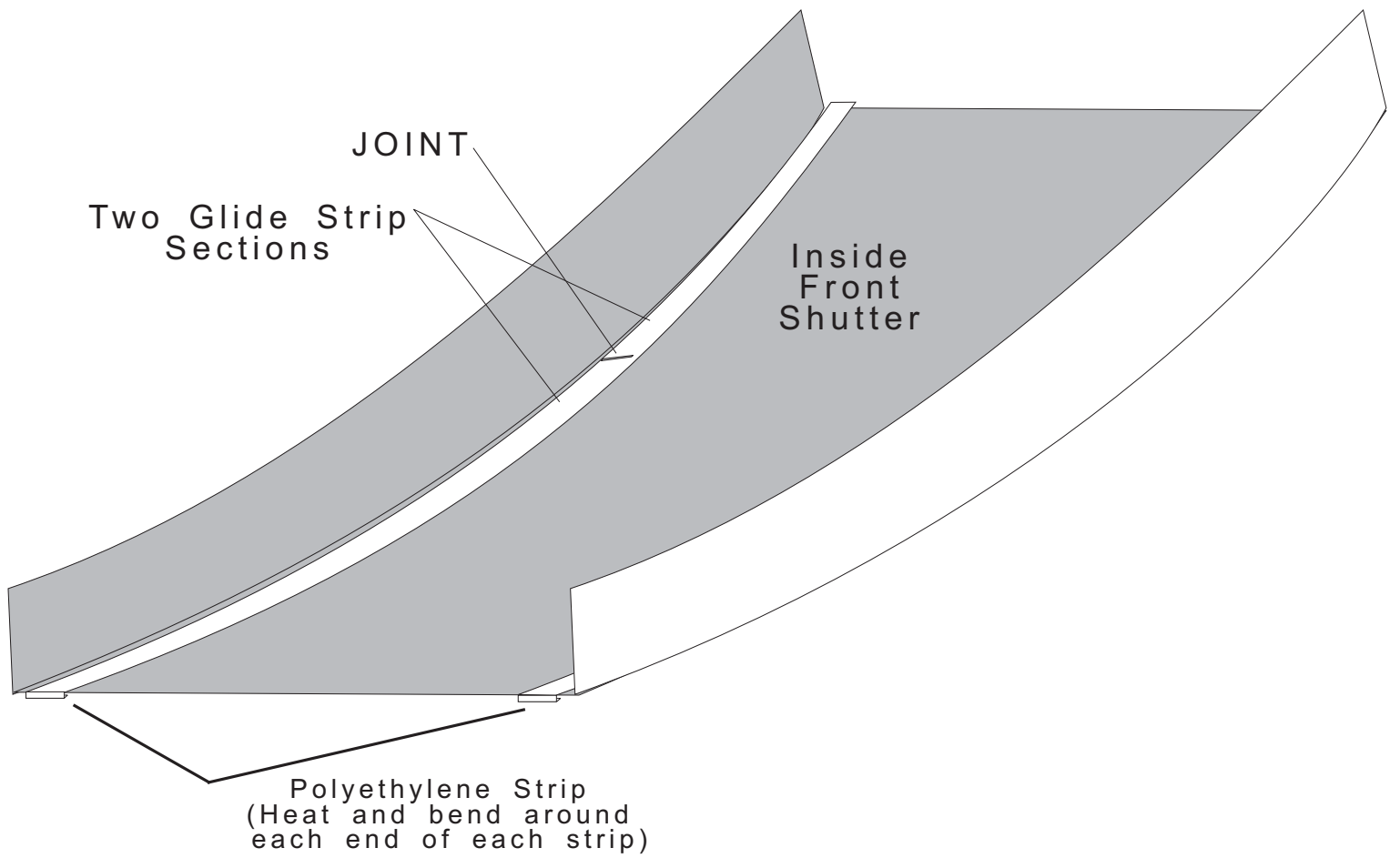

FIG 19 SHUTTER ANTIFRICTION STRIP

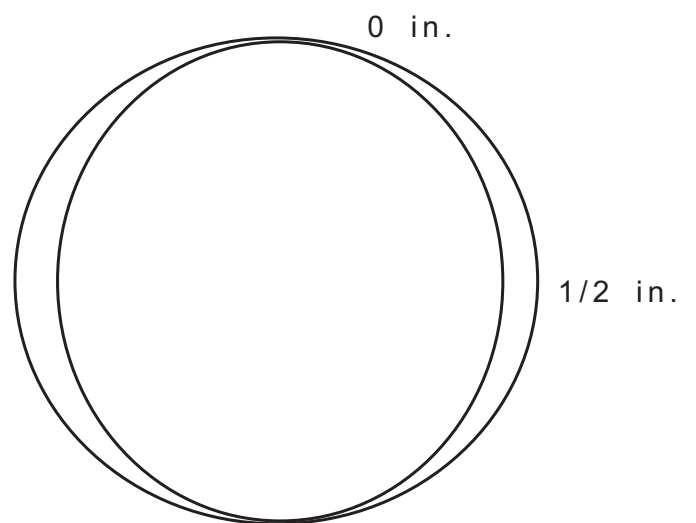
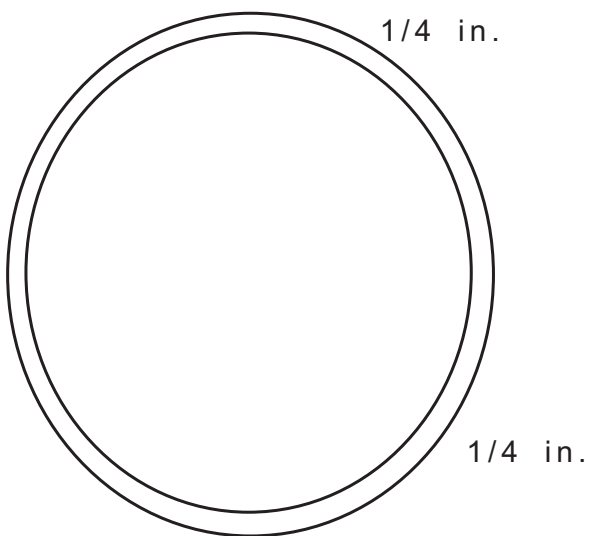
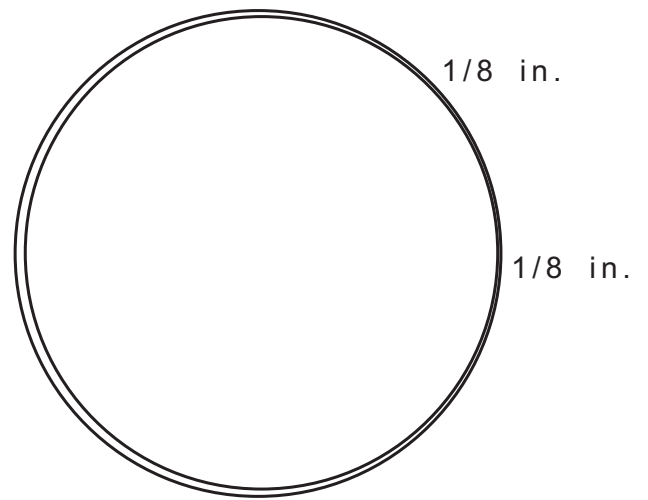
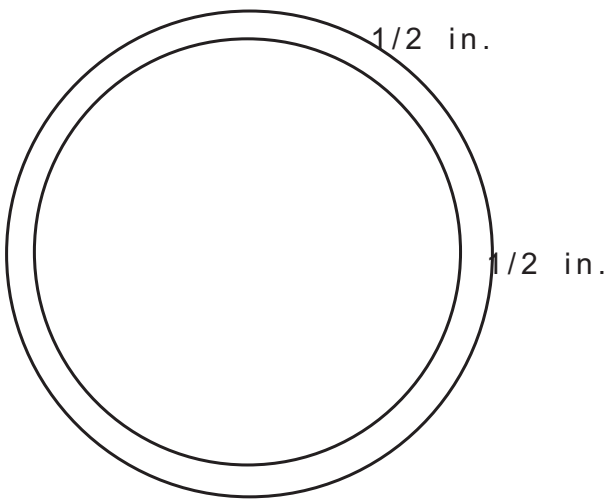
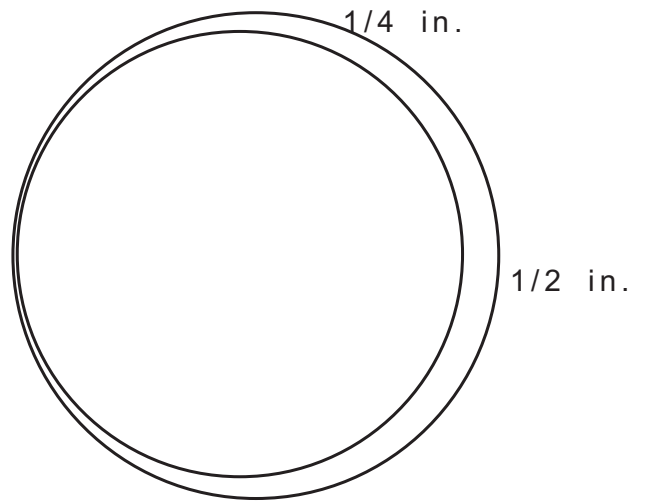
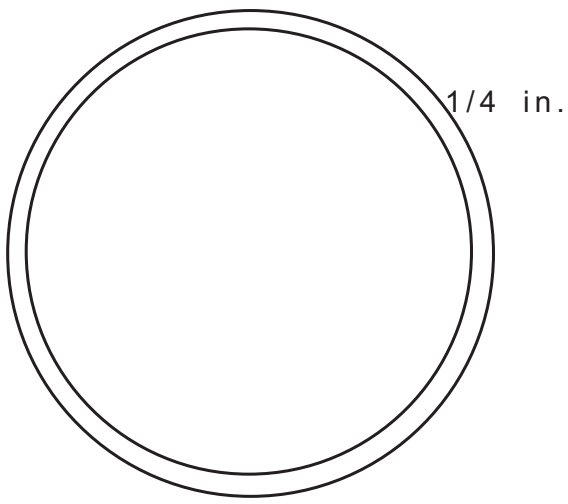
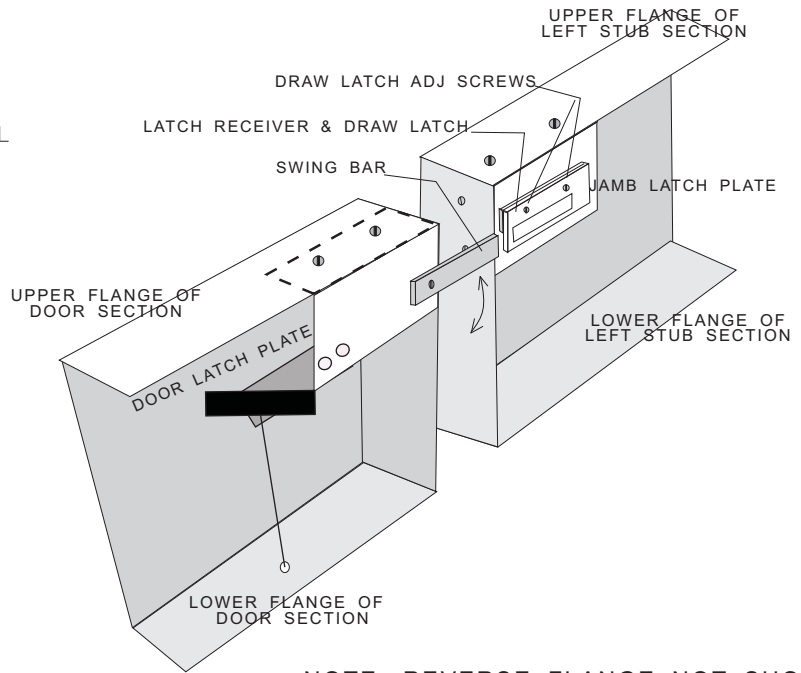
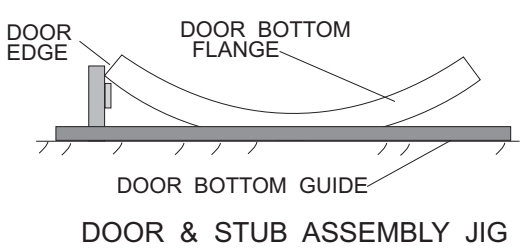

FIG 21 - ROTATION TESTS



NOTE: REVERSE FLANGE NOT SHOWN

SEMIDOOR UPPER BOLT ASSEMBLY

VIEW FROM INSIDE DOME

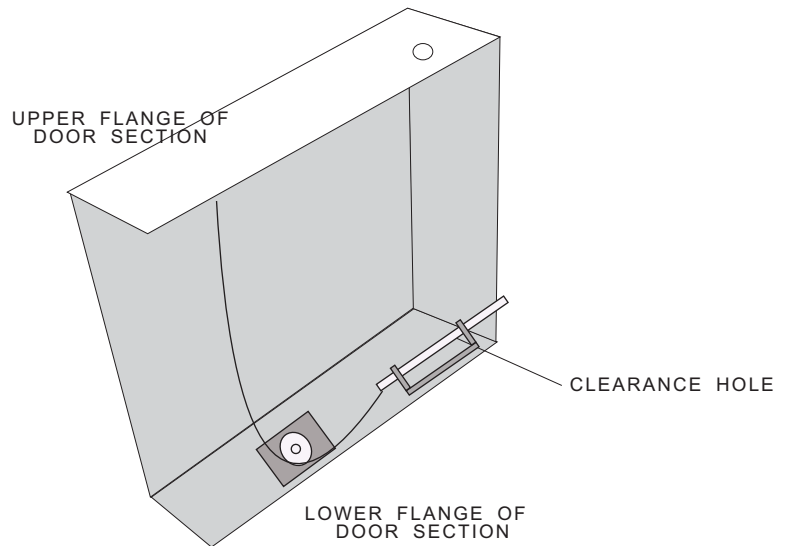
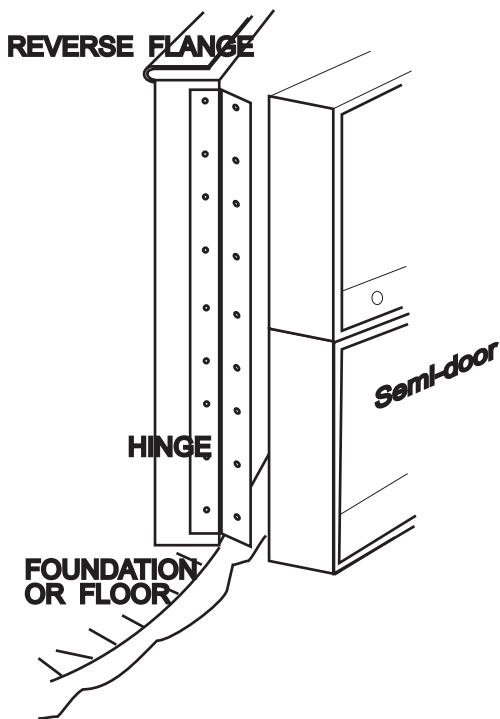

SEMIDOOR LOWER BOLT ASSEMBLY

VIEW FROM INSIDE DOME

FIG. 22 WALL WITH SEMI-DOOR

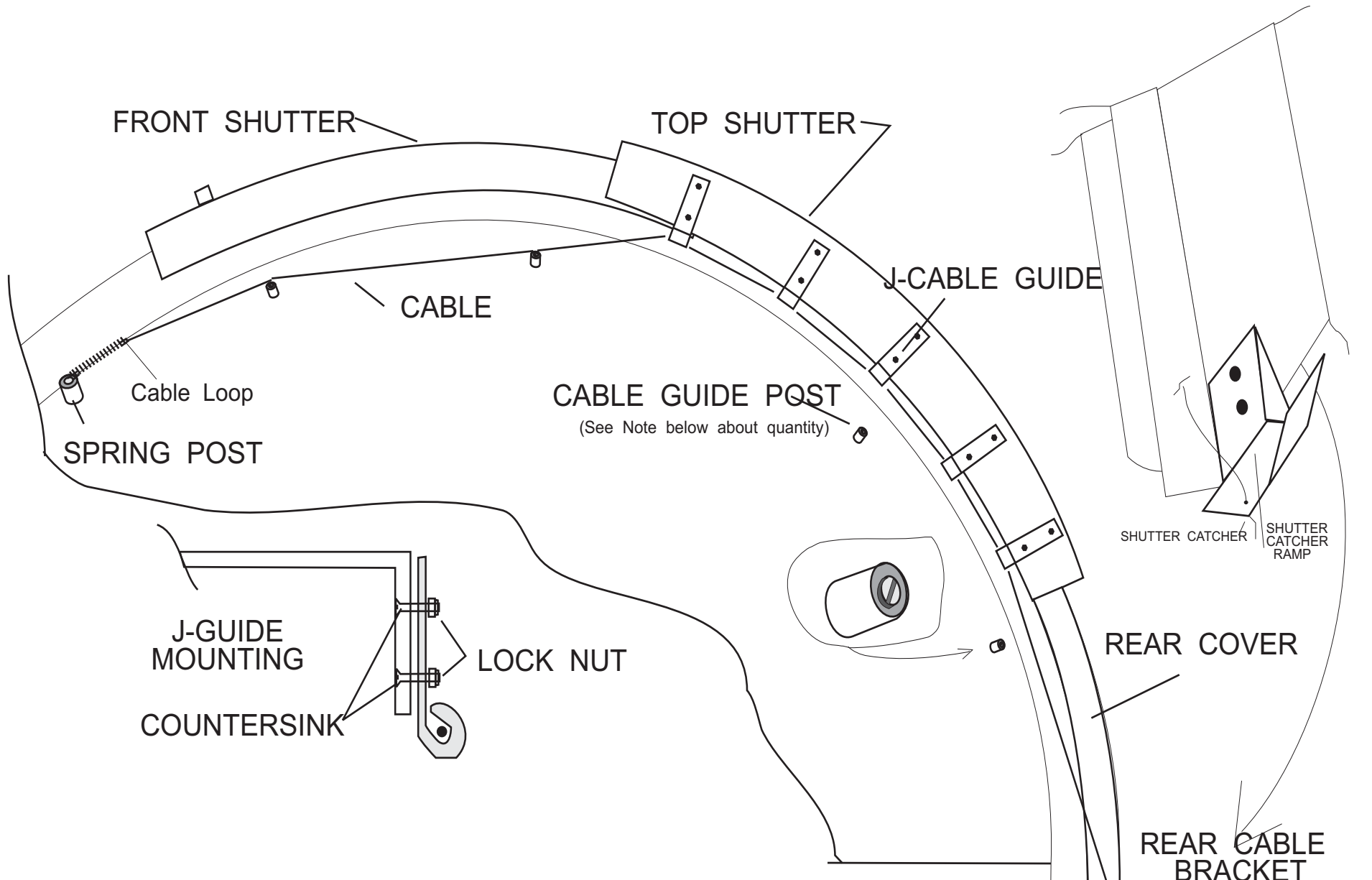

Generic SHUTTER RESTRAINT SYSTEM

FIG 24

Notes:

1. Drawing is generic-different domes use different numbers of parts
2. HD6 Uses four J-guides and four guide posts each side.
3. HD10/PD10 uses five J-guides and four guide posts each side
4. PD15 uses six J-guides and six guide posts each side
5. Space J-guides equally starting about 4" from the ends of the shutter

Note: Cable clamp and spring may be switched end for end. Use rear (Outward) hole

PD117
082101